

Operator's Manual



McELROY

www.mcelroy.com



In-Ditch 48

Fusion Machine

Manual: 4845301
Original Language: English

Revision: B 11/16

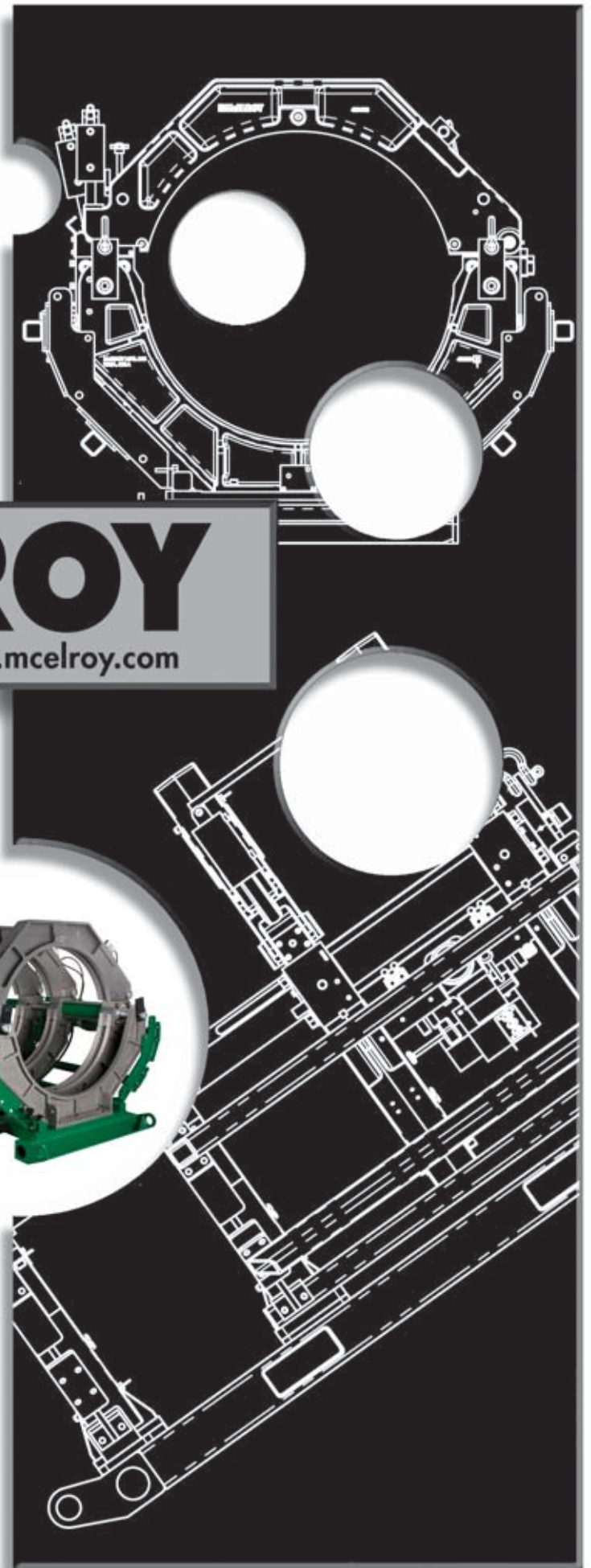

This product and other products could be protected by patents or have patents pending. All the latest patent information is available at patent.mcelroy.com



Introduction



Thank You for purchasing this McElroy product

The In-Ditch 48 fusion machine is designed to butt fuse polyethylene pipe sizes from 16" O.D. (450mm) to 48" O.D. (1200mm). The machine allows the fusion of pipe and fittings using a compact carriage in either a 4-Jaw or 3-Jaw configuration.

If fusing other thermoplastic pipe materials, refer to the pipe manufacturer's fusion procedures or appropriate joining standard.

The machine allows for butt fusion of most fittings without special holders. Mitered inserts are also available for fabricating ells.

With reasonable care and maintenance, this machine will give years of satisfactory service.

Before operating this machine, please read this manual thoroughly, and keep a copy with the machine for future reference. This manual is to be considered part of your machine.

Always return the manual to the literature compartment.

TX02729-11-2-10



McElroy University

For more than 30 years, McElroy has been the only pipe fusion machine manufacturer to continuously offer advanced training. Course offerings are meant to enhance your efficiency, productivity and safety in the proper use of McElroy machines. McElroy University classes are structured so that the skills learned and the machines used in each class closely match the machines found on pipelining jobsites. We offer training at our facility or yours. Our uniquely qualified McElroy University course instructors offer years of industry experience.

Tuition for each course includes lunches, course materials and a certificate of completion. Online registration, as well as up-to-date course offerings and dates, is available at www.mcelroy.com/university

This manual is intended as a guide only and does not take the place of proper training by qualified instructors. The information in this manual is not all inclusive and can not encompass all possible situations that can be encountered during various operations.



MU2-03-13-14



Warranty



LIMITED WARRANTY

McElroy Manufacturing, Inc. (McElroy) warrants all products manufactured, sold and repaired by it to be free from defects in materials and workmanship, its obligation under this warranty being limited to repairing or replacing at its factory and new products, within **5 years** after shipment, with the exception of purchased items (such as electronic devices, pumps, switches, etc.), in which case that manufacturer's warranty applies. Warranty applies when returned freight is prepaid and which, upon examination, shall disclose to have been defective. This warranty does not apply to any product or component which has been repaired or altered by anyone other than McElroy or has become damaged due to misuse, negligence or casualty, or has not been operated or maintained according to McElroy's printed instructions and warnings. This warranty is expressly in lieu of all other warranties expressed or implied. The remedies of the Buyer are the exclusive and sole remedies available and Buyer shall not be entitled to receive any incidental or consequential damages. Buyer waives the benefit of any rule that disclaimer of warranty shall be construed against McElroy and agrees that such disclaimers herein shall be construed liberally in favor of McElroy.

RETURN OF GOODS

Buyer agrees not to return goods for any reason except upon the written consent of McElroy obtained in advance of such return, which consent, if given, shall specify the terms and conditions and charges upon which any such return may be made. Materials returned to McElroy, for warranty work, repair, etc., **must have a Return Material Authorization (RMA) number**, and be so noted on the package at time of shipment. For assistance, inquiry shall be directed to:

McElroy Manufacturing, Inc.
 P.O. Box 580550
 833 North Fulton Street Tulsa, Oklahoma 74158-0550
 PHONE: (918) 836-8611, FAX: (918) 831-9285.
 EMAIL: fusion@McElroy.com

Note: Certain repairs, warranty work, and inquiries may be directed, at McElroy's discretion, to an authorized service center or distributor.

DISCLAIMER OF LIABILITY

McElroy accepts no responsibility of liability for fusion joints. Operation and maintenance of the product is the responsibility of others. We recommend qualified joining procedures be followed when using McElroy fusion equipment.

McElroy makes no other warranty of any kind whatever, express or implied; and all implied warranties of merchantability and fitness for a particular purpose which exceed the aforesaid obligation are hereby disclaimed by McElroy.

PRODUCT IMPROVEMENT

McElroy reserves the right to make any changes in or improvements on its products without incurring any liability or obligation to update or change previously sold machines and/or the accessories thereto.

INFORMATION DISCLOSED

No information of knowledge heretofore or hereafter disclosed to McElroy in the performance of or in connection with the terms hereof, shall be deemed to be confidential or proprietary, unless otherwise expressly agreed to in writing by McElroy and any such information or knowledge shall be free from restrictions, other than a claim for patent infringement, is part of the consideration hereof.

PROPRIETARY RIGHTS

All proprietary rights pertaining to the equipment or the components of the equipment to be delivered by McElroy hereunder, and all patent rights therein, arising prior to, or in the course of, or as a result of the design or fabrication of the said product, are exclusively the property of McElroy.

LAW APPLICABLE

All sales shall be governed by the Uniform Commercial Code of Oklahoma, U.S.A.

Register your product online to activate your warranty:
www.McElroy.com/fusion

(Copy information listed on the machine nameplate here for your records).

Model No. _____

Serial No. _____

Date Received _____

Distributor _____



Table of Contents



Fusion Equipment Safety

Safety Alerts	1-1
Read and Understand.	1-1
General Safety	1-2
Wear Safety Equipment	1-2
Heater is Not Explosion Proof	1-2
Do Not Operate This Machine in a Explosive Atmosphere	1-3
Crush Points	1-3
Electrical Safety	1-3
Units with Hydraulics	1-4
Pipe Handling Safety	1-4
Facer Blades Are Sharp	1-5
Overhead Loads	1-5
Stand Clear.	1-5
Heater is Hot.	1-5
Fusion Procedures	1-6

Overview

Theory of Heat Fusion	2-1
Carriage Assembly.	2-2
Jaw Pivot and Clamp Control.	2-3
Jaw Clamps	2-3
Fusion Power Pack	2-3
Electrical Box (Power Pack)	2-4
Electrical Power (Power Pack).	2-5
Electric Motor (Power Pack)	2-5
Facer	2-5
Hydraulic Manifold Block	2-6
Oil Reservoir	2-6
Quick Disconnects	2-6
Filter and Filler Cap with Breather	2-7
Heater/Facer Stand	2-7
Heater	2-8
Power for Heater	2-8
Heater Stripper	2-9
Spreader Bar.	2-9
Toolbox	2-10

COPYRIGHT © 2016, 2013
 McELROY MANUFACTURING, INC.
 Tulsa, Oklahoma, USA
 All rights reserved

All product names or trademarks are property of their respective owners. All information, illustrations and specifications in this manual are based on the latest information available at the time of publication. The right is reserved to make changes at any time without notice.



Table of Contents



Operation

Read Before Operating	3-1
Before Starting	3-1
Electrical Power	3-2
Hydraulic Pumps	3-2
Prepare Heater	3-3
Jaw Inserts	3-4
Loading Pipe Into Machine	3-5
Closing Jaws	3-5
Positioning Facer	3-6
Begin Facing	3-7
After Facing	3-8
Determine Drag Pressure	3-8
Set Fusion Pressure	3-8
Check for Slippage	3-9
Check Alignment	3-9
Remove Heater from Heater/Facer Stand	3-10
Insert Heater	3-10
Heat Pipe	3-11
Fusing the Pipe	3-11
Open Jaws	3-12
Position Pipe for Next Joint	3-12

Special Operations - 3-Jaw

Overview	4-1
Removing 3-Jaw Carriage	4-1
Lift 3-Jaw Carriage	4-3
Make Fusion Joint	4-4

Special Operations - Upper Jaws

Remove Upper Jaws	5-1
-----------------------------	-----

Special Operations - Hydraulic Clamping

Remove Hydraulic Clamping	6-1
-------------------------------------	-----

Lifting Fusion Machine

Lifting Safety	7-1
Lifting 4-Jaw Skid	7-2
Lifting Carriage from a Side	7-3
Lifting Heater/Facer Skid	7-4
Lifting Fusion Power Pack	7-5



Table of Contents



Maintenance

Preventative Maintenance	8-1
Disconnect Electrical Power	8-1
Washing the Machine	8-1
Check Hydraulic Fluid.	8-1
Change Hydraulic Fluid and Filter	8-2
Adjusting System Pressure	8-2
Grease	8-2
Facer Blades	8-3
Clean Jaws and Inserts	8-3
Installing Butt Fusion Heater Plates	8-3
Clean Heater Surfaces	8-4
Bleeding Air From Hydraulic System.	8-4
Hydraulic Cylinder Cushion.	8-5
Heater Temperature Adjustment	8-6
Fasteners Must Be Tight.	8-6
If Unit Fails to Start (Power Pack)	8-6
Fuji Model PXR3 Temperature Controller Setup.	8-7

Maintenance Checklist

In-Ditch 48 Machine.	9-1
------------------------------	-----

Determine Fusion Pressure

Determine Fusion Pressure	10-1
-------------------------------------	------

Hydraulic Fluids

Hydraulic Fluids	11-1
----------------------------	------

Specifications

In-Ditch 48 Fusion Machine.	12-1
-------------------------------------	------



Fusion Equipment Safety



Safety Alerts

This hazard alert sign  appears in this manual. When you see this sign, carefully read what it says. YOUR SAFETY IS AT STAKE.

You will see the hazard alert sign with these words: DANGER, WARNING, and CAUTION.



WR00051-11-30-92

 **DANGER** Indicates an imminently hazardous situation which, if not avoided, will result in death or serious injury.



 **WARNING** Indicates a potentially hazardous situation which, if not avoided, could result in death or serious injury.



 **CAUTION** Indicates a hazardous situation which, if not avoided, may result in minor or moderate injury.



In this manual you should look for two other words: **NOTICE** and **IMPORTANT**.

NOTICE: can keep you from doing something that might damage the machine or someone's property. It may also be used to alert against unsafe practices.

IMPORTANT: can help you do a better job or make your job easier in some way.

TX00030-12-1-92

Read and Understand

Do not operate this equipment until you have carefully read, and understand all the sections of this manual, and all other equipment manuals that will be used with it.

Your safety and the safety of others depends upon care and judgment in the operation of this equipment.

Follow all applicable federal, state, local, and industry specific regulations.

McElroy Manufacturing, Inc. cannot anticipate every possible circumstance that might involve a potential hazard. The warnings in this manual and on the machine are therefore not all inclusive. You must satisfy yourself that a procedure, tool, work method, or operating technique is safe for you and others. You should also ensure that the machine will not be damaged or made unsafe by the method of operation or maintenance you choose.



WR00052-12-1-92

TX02946-4-15-09



Fusion Equipment Safety



General Safety

Safety is important. Report anything unusual that you notice during set up or operation.

LISTEN for thumps, bumps, rattles, squeals, air leaks, or unusual sounds.

SMELL odors like burning insulation, hot metal, burning rubber, hot oil, or natural gas.

FEEL any changes in the way the equipment operates.

SEE problems with wiring and cables, hydraulic connections, or other equipment.

REPORT anything you see, feel, smell, or hear that is different from what you expect, or that you think may be unsafe.



SAFE1ST-1222-92

TX00114-4-22-93

Wear Safety Equipment

Wear a hard hat, safety shoes, safety glasses, and other applicable personal protective equipment.

Remove jewelry and rings, and do not wear loose-fitting clothing or long hair that could catch on controls or moving machinery.

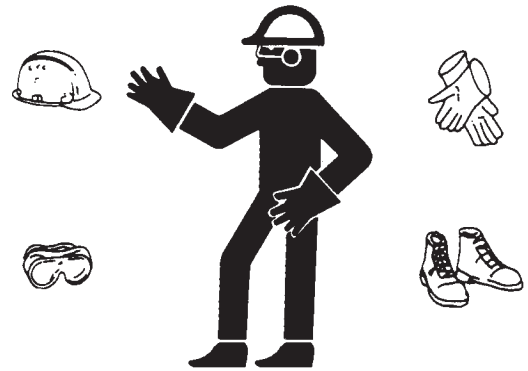

WR00053-122-92

TX00032-4-7-93

Heater is Not Explosion Proof

⚠ DANGER This heater is not explosion proof. Operation of heater in an explosive atmosphere without necessary safety precautions will result in serious injury or death.

If operating in an explosive atmosphere, the heater should be brought up to temperature in a safe environment, then unplugged before entering the explosive atmosphere for fusion.



WR00034-11-30-92

TX00100-04-28-14



Fusion Equipment Safety



Do Not Operate This Machine in a Hazardous Environment



Electric motors and heaters are not explosion proof. Operation of these components in an explosive atmosphere will result in serious injury or death.

TX00796-04-11-14



WR00080-4-12-93

Crush Points



Hydraulically operated equipment is operated under pressure. Anything caught in the machine will be crushed. Keep fingers, feet, arms, legs, and head out of the machine while operated.

TX03004-8-11-09



WR00012-12-4-92

Electrical Safety



Always ensure equipment is properly grounded. It is important to remember that you are working in a wet environment with electrical devices. Proper ground connections help to minimize the chances of an electric shock.

Frequently inspect electrical cords and unit for damage. Have damaged components replaced and service performed by a qualified electrician.

NOTICE: Always connect units to the proper power source as listed on the unit, or in the owner's manual.



Disconnect the machine from the power source before attempting to service the control panel. Failure to disconnect the power could result in electric shock. Refer service to a qualified technician.

TX03003-10-12-10



WR00055-4-7-93



WR00025-11-30-92

Units With Hydraulics

It is important to remember that a sudden hydraulic oil leak can cause serious injury, or even be fatal if the pressure is high enough.

⚠ WARNING Escaping fluid under pressure can penetrate the skin causing serious injury. Keep hands and body away from pinholes which eject fluid under pressure. Use a piece of cardboard or paper to search for leaks. If any fluid is injected into the skin, it must be immediately removed by a doctor familiar with this type of injury.

⚠ WARNING Unwanted movement of the machine could result in serious injury or damage to machine. Unwanted movement of the machine may take place if levers do not match machine state when the machine power is turned on.

NOTICE: Wear safety glasses, and keep face clear of area when bleeding air from hydraulic system to avoid spraying oil into eyes.



WR00078-4-8-93

TX03007-10-12-10

Pipe Handling Safety

⚠ WARNING Do not position yourself under supported or raised pipe. Pipe is heavy and could result in serious injury or death.

⚠ WARNING Pipe that is bent can store a great amount of energy. Do not bend and force the pipe into the machine. A bent pipe with stored energy could cause serious injury or death when that energy is released.

It is recommended that the pipe is always held securely by either being clamped securely in the fusion machine jaws or attached to a lifting device.

NOTICE: Do not leave machine unattended to unauthorized personnel. Operation of the machine by unauthorized personnel could damage the machine.

Keep persons that are not involved in handling pipe away from handling operations. Keep away from the pipe when the pipe and handling equipment are in motion. When in motion, all persons involved in handling pipe should be able to see all other persons at all times. If any handling person is not in sight, immediately stop moving equipment and pipe and locate that person. Do not continue until all persons are accounted for and in sight.

Never push, roll, dump or drop pipe lengths, bundles or coils off the truck, off handling equipment or into a trench. Always use appropriate equipment to lift, move and lower the pipe.

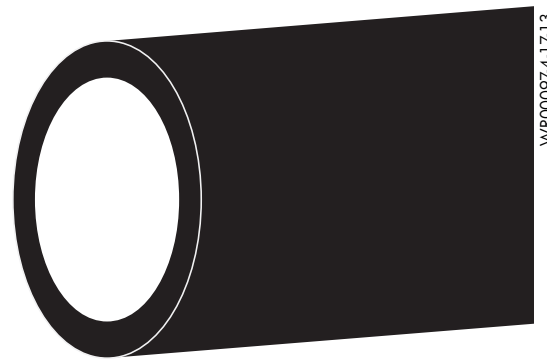

WR00097-4-17-13

TX04882-03-14-16-



Fusion Equipment Safety



Facer Blades Are Sharp



Facer blades are sharp and can cut. Never attempt to remove shavings while the facer is running, or is in the facing position between the jaws. Use care when operating the facer, and when handling the unit.

NOTICE: Disconnect power from the facer, and remove the facer blades before attempting any maintenance or adjustment.

NOTICE: Never extend the blade beyond the inner or outer circumference of the facer.

TX02378-1-24-05

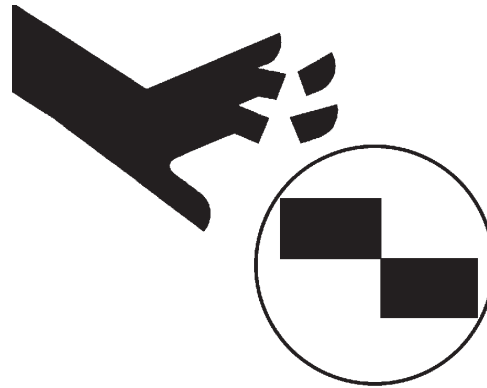

WR00073-4-6-93

Overhead Loads



The heater and facer are loaded into the fusion machine from overhead. Do not stand under loads that are lifted overhead. Overhead loads could fall causing serious injury or death.

TX04455-9-19-12



WR00014-3-18-13

Stand Clear



Jaws pivot rapidly and can cause severe bodily injury if someone is standing too close. All personnel must stand clear of machine when operating.

Be aware of yourself and others when operating this machine and when sections of pipe are being moved.

TX04547-3-18-13



WR00096-3-18-13

Heater Is Hot



The heater is hot and will burn clothing and skin. Keep the heater in its insulated heater shroud when not in use, and use care when heating the pipe.

NOTICE: Use only a clean non-synthetic cloth to clean the heater plates.

TX04244-10-12-10



WR00030-2-10-93



Fusion Equipment Safety



Fusion Procedures

Obtain a copy of the pipe manufacturer's procedures or appropriate joining standard for the pipe being fused. Follow the procedure carefully, and adhere to all specified parameters.

NOTICE: Failure to follow pipe manufacturer's procedure could result in a bad joint. Always follow pipe manufacturer's procedures.

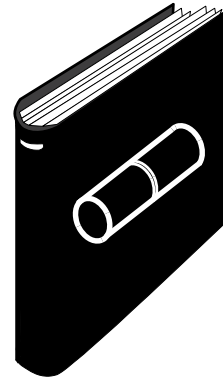

WR00079-2796

TX04469-10-24-12

Theory of Heat Fusion

The principle of heat fusion is to heat two surfaces to a designated temperature, and then fuse them together by application of force. This develops pressure which causes flow of the melted materials, which causes mixing and thus fusion. When the thermoplastic material is heated, the molecular structure is transformed into an amorphous condition. When fusion pressure is applied, the molecules from each thermoplastic part mix. As the joint cools, the molecules return to their form, the original interfaces are gone, and the fitting and pipe have become one monolithic unit. A strong, fully leak tight connection is the result.

The principal operations include:

- Clamping** The pipe pieces held axially to allow all subsequent operations to take place.
- Facing** The pipe ends must be faced to establish clean, parallel mating surfaces perpendicular to the centerline of the pipes.
- Aligning** The pipe ends must be aligned with each other to minimize mismatch or high-low of the pipe walls.
- Heating** A melt pattern that penetrates into the pipe must be formed around both pipe ends.
- Joining** The melt patterns must be joined with a specified force. The force must be constant around the interface area.
- Holding** The molten joint must be held immobile with a specified force until adequately cooled.
- Inspecting** Visually examine the entire circumference of the joint for compliance with standards established by your company, customer, industry, federal, state, or local regulations.



PH012692-1-98

Carriage Assembly

The 4-Jaw skid has 4 hydraulically operated jaws with hydraulic clamping. The 4-Jaw skid can be lowered into a ditch for in-ditch operations. The 4-Jaw skid has forklift pockets on its skid if using a forklift is preferred.

A 3-Jaw carriage can be separated from the 4 Jaw skid for use in close quarters fusion operations and fusions to tees and ells. The upper jaws and hydraulic clamping can be removed so the carriage can be maneuvered under a pipe.

Both configurations are hydraulically powered from a hydraulic power unit.



4-Jaw Carriage



3-Jaw Carriage

Jaw Pivot and Clamp Control

Arrows on valves indicate direction of control lever movement for operation required.

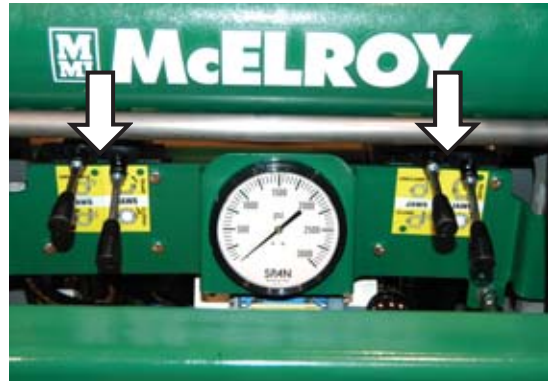

PH04833-3-11-13

TX00885-3-7-96

Jaw Clamps

Jaw clamps are hydraulically operated for clamping and unclamping the upper jaws.

There is a handle connecting both clamping cylinders that is used for lowering the clamps away from the jaws.



PH04855-4-5-13

TX00887-3-7-96

Fusion Power Pack

The Power Pack is mounted on a skid and has a lifting eye for lifting of the entire Power Pack. The Power Pack skid has forklift pockets on its skid if using a forklift is preferred. The Power Pack supplies electrical power and hydraulics for the carriage, heater, and facer. All cables and hoses are stored on storage hooks attached to the sides of the unit.

There is an electrical box on the end of the Power Pack that has all the controls for Power Pack and heater.



PH04827-3-11-13

TX04548-4-17-13

Electrical Box (Power Pack)

Control Panel

1. **Temperature Adjustment.** Digital controller used to set heater temperature.
2. **Reverse Phase Relay.** Interrupts power and prevents pump from turning the wrong direction.
3. **Volt Meter.** Displays incoming voltage from the selected phase of the power source.
4. **Volt Meter Selector Switch.** Allows for selecting each incoming phase of a 3-phase electrical system.
5. **Hour Meter.** Registers total hours hydraulic pump has been used.
6. **Stop - Hydraulic Pump.** Shuts off power to the hydraulic pump.
7. **Start - Hydraulic Pump.** Turns power on to the hydraulic pump.
8. **Heater On/Off.** Turns electrical power on and off to heater.



WARNING Disconnect the machine from the power source before attempting to service the control panel. Failure to disconnect the power could result in electric shock. Refer service to a qualified technician.

To open the electrical box, loosen the screws on the top and sides of the box to open it.

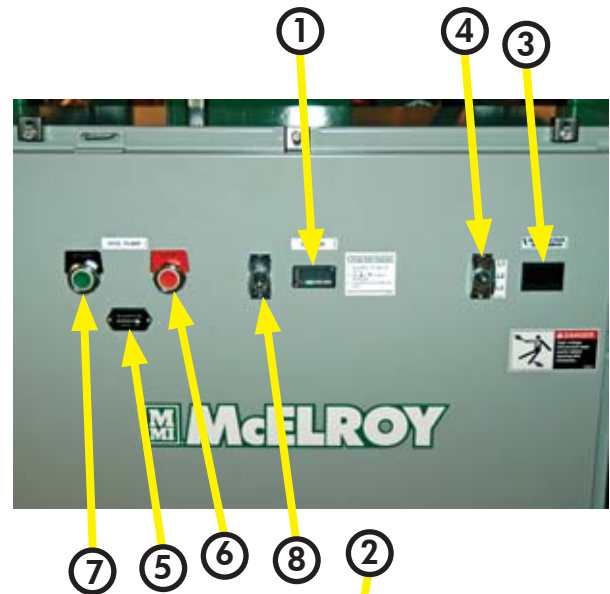

PH04890-3-11-13



PH04890-3-11-13

Electrical Power (Power Pack)



Electric motors and heaters are not explosion proof. Operation of these components in an explosive atmosphere will result in serious injury or death.

See **Specifications** section of this manual for power requirements. Ensure proper ground for the electrical system.



PH04861-3-11-13

TX04588-11-11-16

Electric Motor (Power Pack)

The pump motor is a totally enclosed fan cooled motor for long dependable life.



Electric motors are not explosion proof. Operation of these components in an explosive atmosphere will result in serious injury or death.



PH04860-3-11-13

TX04550-11-11-16

Facer

The facer is a rotating planer-block design. The blade holders each contain four cutter blades. The block is chain driven (enclosed in lubricant) by a hydraulic motor.

The facer has a locking mechanism that locks the facer to the stand or the guide rod of the carriage.

The facer on/off switch is on the facer near the facer locking handle.



PH04851-3-11-13

TX04551-4-17-13

Hydraulic Manifold Block

Mounted on this block are a carriage directional control valve, a pressure reducing selector valve, three pressure reducing valves, a 3000 psi gauge, and a DataLogger® port.

- A) The carriage control valve, mounted on the top of the manifold, determines whether the carriage is moving left, right, or is in neutral.
- B) A 3000 psi carriage pressure gauge is mounted on a bracket above the manifold. This gauge indicates pressure at the carriage control valve.
- C) The selector valve, mounted on the upper left of the manifold, selects a reduced pressure from one of the pressure reducing valves.

Each pressure reducing valve is labeled with a different function:

- D) The top valve adjusts facing pressure to a maximum of 800 psi.
- E) The middle valve adjusts heating pressure to a maximum of 800 psi.
- F) The bottom valve adjusts fusion pressure to a maximum of 3000 psi or system pressure, whichever is lower.
- G) DataLogger port - Optional DataLogger sold separately.

TX04589-4-17-13



PH048323-11-13

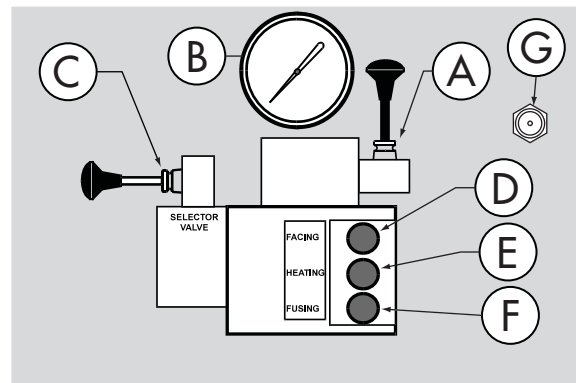

CD00182E3-11-13

Oil Reservoir

The oil reservoir is located under the hood of the Power Pack. The oil level sight gauge is located on the reservoir behind the electrical box. It includes a thermometer which indicates oil temperature.

Fill to the top of the sight gauge when the oil is cool.

Refer to the "Hydraulic Fluids" section of this manual for hydraulic oil recommendations.

Never allow dirt or other foreign matter to enter the open tank.

TX04552-3-18-13

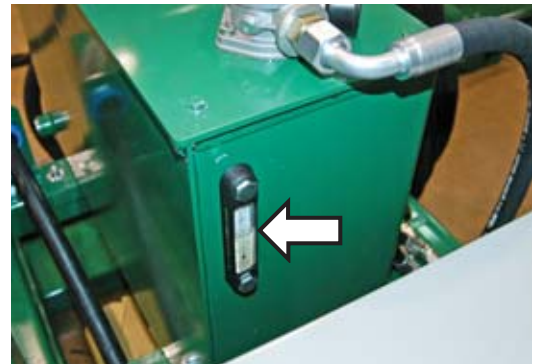

PH04856-3-11-13

Quick Disconnects

The machine is equipped with self relieving quick disconnects. The hoses will not hold pressure after being disconnected. When the quick disconnects are not connected, use the dust caps to cover the fittings on the hoses and on the machine and Power Pack.



PH04865-4-17-13

TX04590-4-17-13

Filter and Filler Cap with Breather

To access the filler cap, remove the four bolts of the access cover. The filter and filler cap is located under the Power Pack cover on top of the hydraulic reservoir.

The cap has a breather hole on the top of the cap.

This machine is equipped with a 10 Micron filter on the return side of the hydraulic system.

Change filter when the indicator gauge (B) is not in the green range.

The reservoir is filled by removing the cap (A) and the filter.

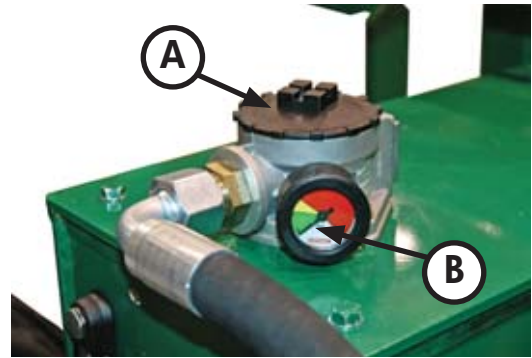

PH048573-1-1-13

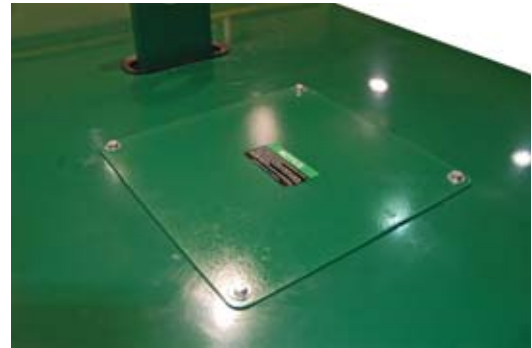

PH048504-1-7-13

TX04553-3-18-13

Heater/Facer Stand

The heater/facer stand is skid mounted and houses the facer on one side and the heater on the other side. The heater side has a heater cover that opens like a gate. The heater cover swings out away for the heater for heater removal.

The stand has a folding transport arm that can be moved up into position and has two clamps that secure the heater and facer in the stand.



PH04849-3-1-1-13



PH04898-3-28-13

TX04579-4-17-13

Heater

The heater is equipped with butt fusion heater plates, coated with an antistick coating.

⚠ DANGER This heater is not explosion proof. Operation of heater in an explosive atmosphere without necessary safety precautions will result in serious injury or death.

The heater is stored in the heater/facer stand when the heater is not in use.



PHO4854-3-11-13

TX04554-11-11-16

Power for Heater

The heater power cord and RTD cable has receptacles on the heater and has a receptacle on the Power Pack. Tighten coupling nut after plugging into receptacles.

The power switch for the heater is located on electrical box of the Power Pack.

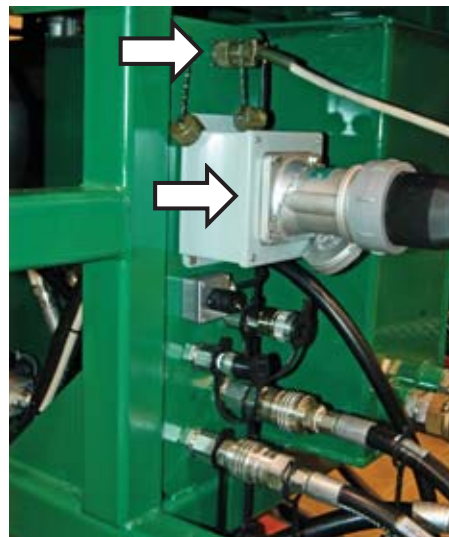

PHO4831-3-11-13

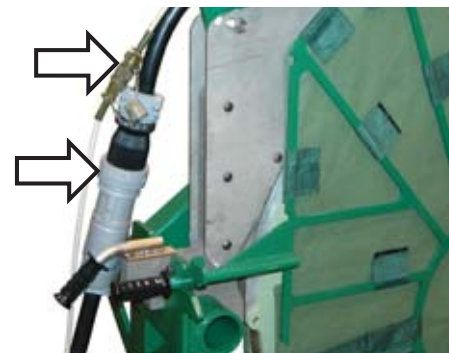

PHO4880-3-11-13

TX04555-3-18-13

Heater Stripper

There is a heater stripper attached to the inner jaws of the carriage. The stripper assists in separating the pipe ends from the heater surfaces. The heater rests in the notch on the top of the stripper. The stripper allows a shorter stripping distance on the fixed jaw side to allow stripping when there is no space available outside the inner fixed jaw of the 3-Jaw carriage.

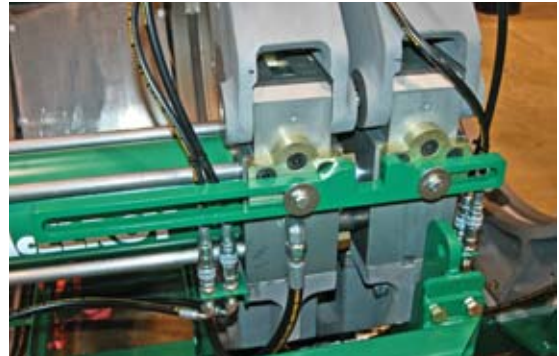

PH04900-3-28-13

A second stripper (if equipped) allows more stripping distance from the inner fixed jaw.

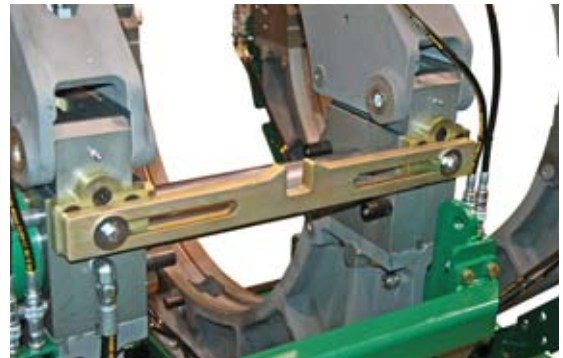

PH04854-3-11-13

The stripper that is not in use is stored on the top guard rail next to where the stripper mounts on to the jaws.

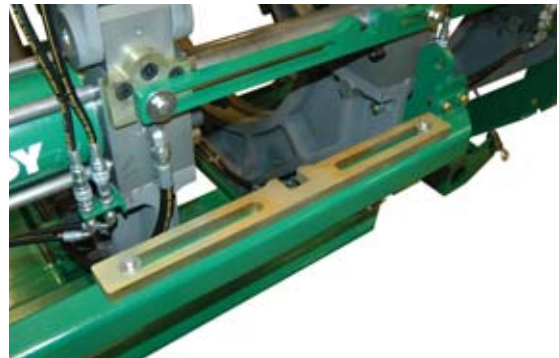

PH04927-4-5-13

TX04568-3-28-13

Spreader Bar

The spreader bar is used to lift the carriage in either the 4-Jaw or 3-Jaw configurations. The spreader bar has lifting cables.

NOTICE: Never use this spreader bar for any other purpose. You could damage the spreader bar and machine.



PH04897-4-17-13

TX04591-4-17-13

Toolbox

The toolbox is mounted to the heater/facer stand. The toolbox contains the machine operator's manual, additional lifting shackles, jaw lifter, insert pins, and drift for removing upper jaws.

Any hardware that is not being used should be stored in the toolbox so it will not be misplaced or lost.



PH04928-4-17-13

TX04592-4-17-13



Operation



Read Before Operating

Before operating this machine, please read this manual thoroughly and keep a copy available for future reference.

Return manual to the protective storage box when not in use. This manual is to be considered part of your machine.



Stop-1228-95

TX00401-9-15-94

Before Starting

Connect the hydraulic hoses to the carriage and facer from the Power Pack.

IMPORTANT: Open the pressure relief valve before connecting the hoses and starting the machine. This will allow for easier connection of hoses and easy start of the hydraulic pumps.

Connect the power cable for the heater first and then connect the RTD cable between the heater and the Power Pack.

Connect the electrical cables to the facer.

NOTICE: Plug the facer cable last and remove first before connecting and disconnecting facer hoses. This will prevent damage to the cable from supporting the weight of the hoses.

Before starting this machine make sure that the carriage directional control is centered. The heater and facers switches should be in OFF position.

The clamp valves should be in the centered position, the jaw pivot valves should match the current position of the jaws.

This will prevent any unwanted movement upon starting of Power Pack.



WARNING Unwanted movement of the machine could result in serious injury or damage to machine. Unwanted movement of the machine may take place if valves do not match machine state when the machine power is turned on.

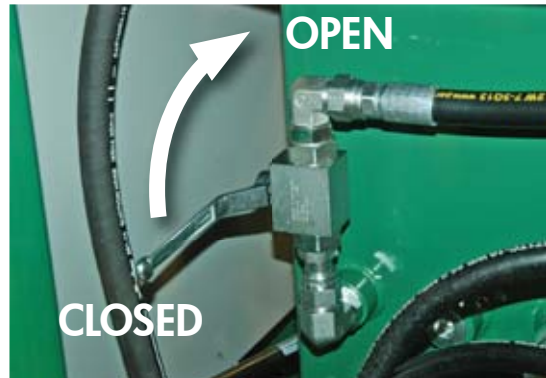

PH04937-10-15-13

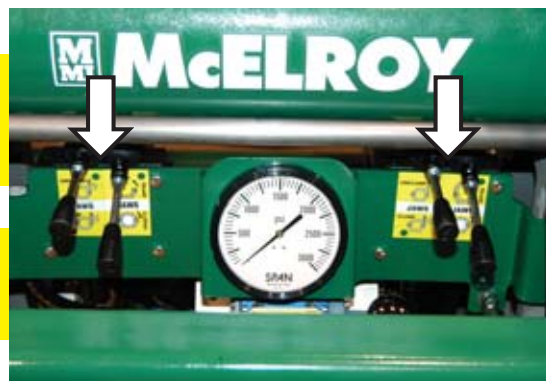
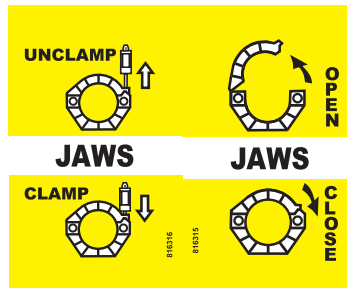

PH04833-3-11-13

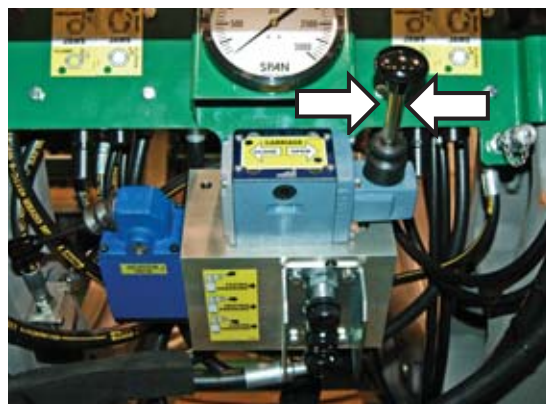

PH04832-3-11-13

TX04556-10-15-13



Operation



Electrical Power

NOTICE: Low voltage will damage unit. Connect unit to proper electrical power source. Ensure proper ground for electrical system.

If unit fails to start, check to see if the light on the reverse phase relay is on. If not, disconnect the power source and switch any two incoming power leads and try again. If the unit still doesn't start, call qualified service personnel for assistance.

The reverse phase relay ensures correct rotation of the pump motor so damage to the hydraulic system does not occur.

TX04557-3-18-13

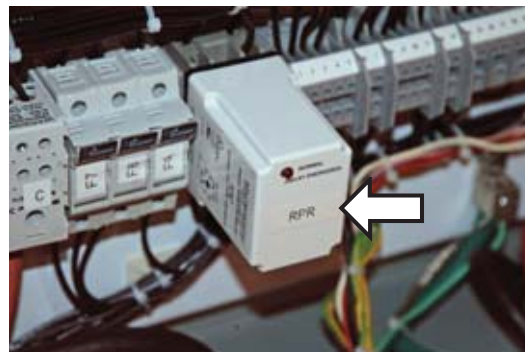

PH04859-3-11-13

Hydraulic Pumps

Turn on hydraulic pumps by pushing start button.

Close the pressure relief valve or the system will not build pressure.

System pressure gauge reading should be 3000 psi.

The large pump is the main hydraulic pump for the machine. The second pump runs the facer and cooling circuit.

When shutting off the hydraulic pumps, open the pressure relief valve to relieve pressure in hydraulic hoses for easy disconnection.

NOTICE: Do not stop and quickly restart the Power Pack. Allow the system pressure gauge to go to zero before restarting the Power Pack. Quickly restarting with pressure in the Power Pack will damage the Power Pack.

The gauge for the facer pump is located to side of the hydraulic reservoir. The relief valve is factory set to 2700 PSI to prevent damage to the pump.

NOTICE: Do not adjust the relief valve. It could cause damage to the pump.



PH04830-3-11-13

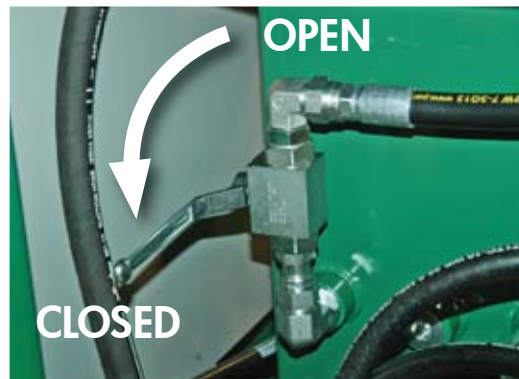

PH04937-10-15-13

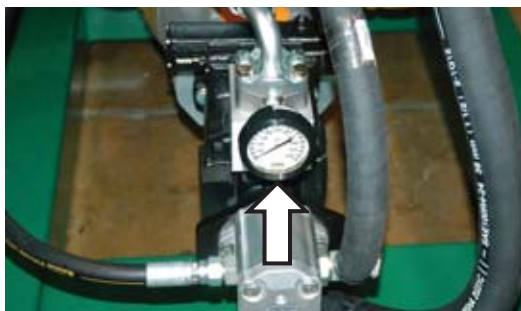

PH04878-3-11-13

TX04558-10-15-13



PH04858-4-17-13

Prepare Heater

DANGER

Heater is not explosion proof. Operation of heater in an explosive atmosphere without necessary safety precautions will result in serious injury or death.

Make sure butt fusion heater plates are properly installed.

NOTICE: Non-coated heaters should never be used without butt fusion heater plates installed. Refer to the "Maintenance" section of this manual for installation procedure.



PH04849-3-11-13

If the heater/facer stand is secured for transport, unclamp the heater and facer. Remove the pin securing the transport arm. Rotate the transport arm down to the horizontal position and replace the pin, locking the arm.

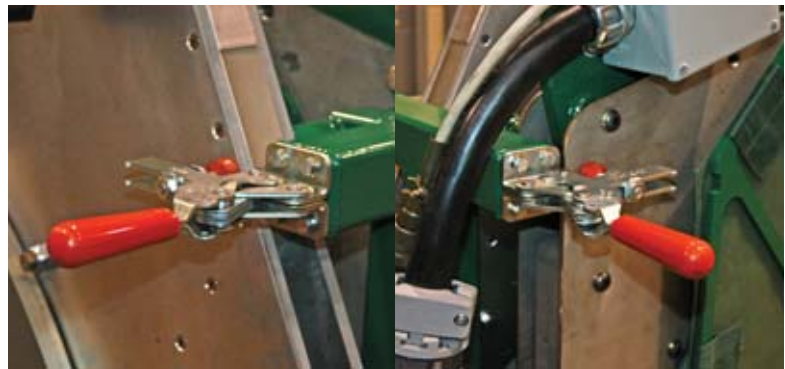

PH04838-3-11-13

PH04837-3-11-13



PH04898-3-28-13



PH04899-3-28-13

Prepare Heater (continued)

Switch heater on using the switch on the electrical box of the Power Pack. Adjust heater temperature to required setting.

Allow heater to warm-up to operating temperature.

Refer to the "Maintenance" section of this manual for instructions how to adjust heater temperature.

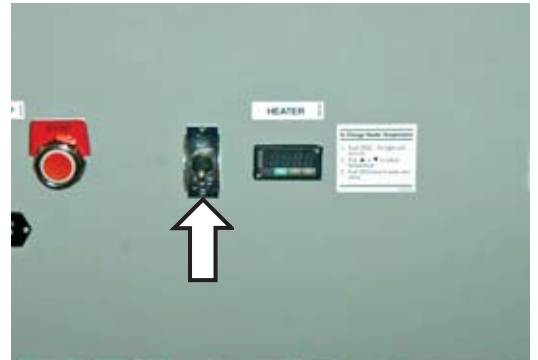

PH04830-3-11-13

The heater cover can be opened to inspect and easily remove the heater. The cover is latched with a locking pin. To open the cover, pull the pin locking the latch. Lift the latch and open the cover.

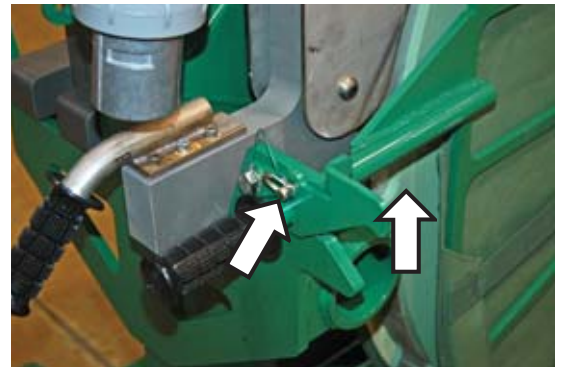

PH04838-3-11-13



PH04854-3-11-13

TX04559-11-11-16

Jaw Inserts

Install appropriate size jaw inserts for the pipe that is being fused. The inserts are held in place by detent pins.

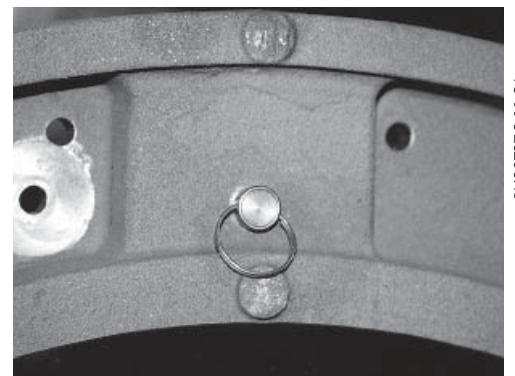

PH00737-3-11-96

TX01660-8-19-99



Operation



Loading Pipe into Machine

Position pipe with enough material protruding past the jaw faces to allow for facing of the pipe end.

WARNING Plastic pipe is heavy. If loaded or lifted improperly, it could crush or kill. Handle load carefully with proper rigging and equipment of adequate load rating.

WARNING Pipe that is bent can store a great amount of energy. Do not bend and force the pipe into the machine. A bent pipe with stored energy could cause serious injury or death when that energy is released.

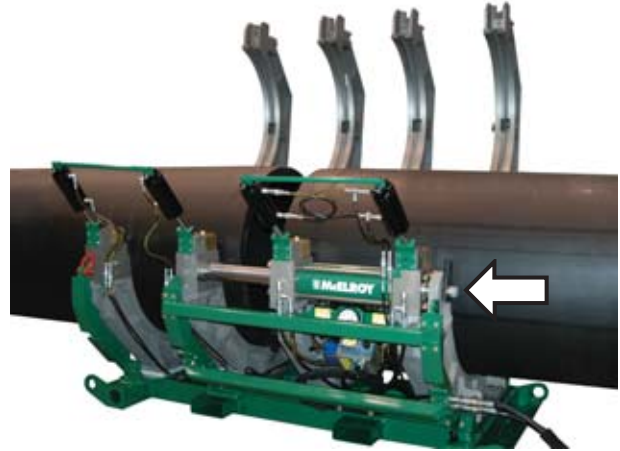

PH02224-8-22-01

TX04560-3-18-13

Closing Jaws

Move the jaw valve control lever to Close position.

Move the clamp cylinders into the vertical position and then move the jaw clamp control valve lever to the Clamp position.

NOTICE: The jaw clamping cylinders are designed to clamp when in the upright position, evenly applying pressure over the entire base of the cylinder. Always ensure the clamping cylinder is upright over the clamping pad of the jaw before clamping the jaw. Damage to the cylinder and jaw can occur if not clamped properly.

Clamp marks on the bottom of the cylinder are an indication that the cylinder was not in the proper position when clamped down.

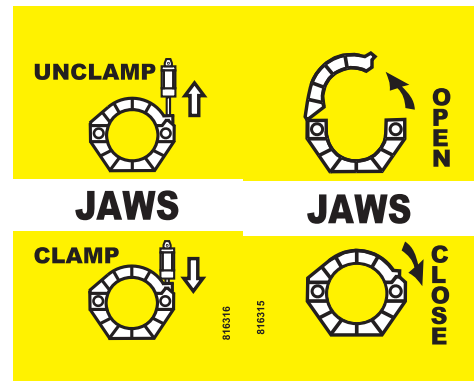

PH04855-3-15-13

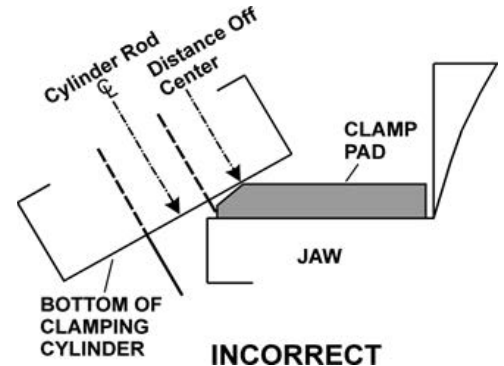
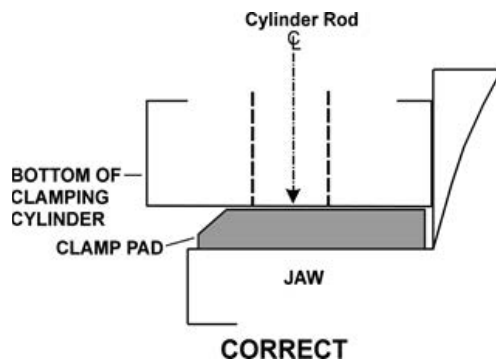

PH04855-3-15-13

PH04855-3-15-13

TX02645-10-15-13

Positioning Facer

Remove the pin from the facer latch and unlatch the facer from the heater/facer stand. Replace the pin to lock the latch in the open position.

Attach a lifting device of adequate rating to the lifting eye of the facer.



PH04851-3-15-13



PH04851-3-15-13

PH04851-3-15-13

As the facer is lifted from the stand, slide the facer guide rod bracket from the stand until it is clear using the handle of the facer latch.



PH04871-3-15-13

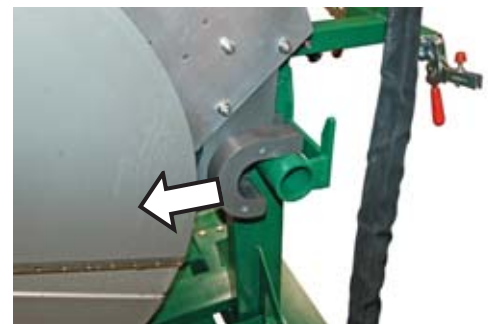

PH04870-3-15-13

Positioning Facer (continued)

Move the facer into position over the carriage. Lower the facer between the pipe ends on the carriage. Once the facer reaches the guide rods of the carriage slide the guide bracket over the guide rod using the handles on the front or back of the facer and lower until the facer rests on the guide rods.

CAUTION Keep hands clear of the facer while moving into position. Use the handles provided on the facer. Failure to do so could result in minor injury.

Remove the pin from the facer latch and latch the facer to the guide rod. Replace the pin to lock the latch to the locked position.

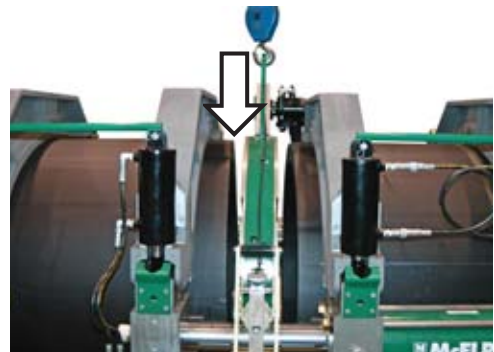

PH04866-3-15-13

TX04561-3-25-13

Begin Facing

Turn facer on by using the switch near the facer latch.

Move the selector valve on the hydraulic manifold block to the top (facing pressure) position.

The facing pressure should be set as low as possible while still facing pipe. Excessive facing pressure can damage the facer. It may be necessary to adjust the carriage pressure.

WARNING Facer blades are sharp and can cut. Never attempt to remove shavings while the facer is running, or is in the facing position between the jaws. Use care when operating the facer, and when handling the unit.

Activate the carriage control valve and move the carriage to the left to begin facing. Continue to face the pipe until the rest buttons on the jaws bottom out on the facer rest buttons.

IMPORTANT: Always face the pipe until the rest buttons are in contact with the rest buttons on the facer.



PH04884-3-25-13

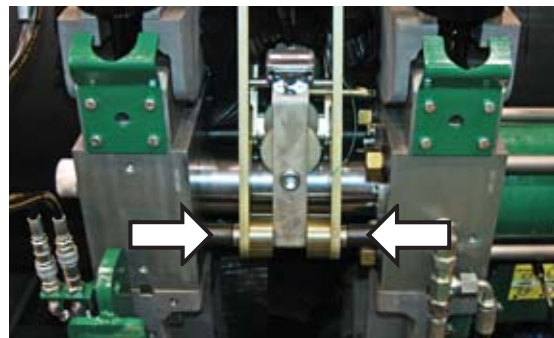

PH04867-3-15-13

TX04562-3-25-13



Operation



After Facing

Turn facer switch off. Move carriage all the way to the right. Center the facer in between the pipe ends to avoid dragging facer stops on the pipe ends. Unlatch the facer latch and lock in the open position. Lift the facer out of the carriage. Move the facer back into the heater/facer stand.

Clean shavings out of pipe ends and from between the jaws. Do not touch faced pipe ends.

⚠ WARNING Turn the Power Pack off if it is necessary to enter the unit for maintenance or chip removal. Death or serious injury could result if the hydraulics are activated while in the unit.

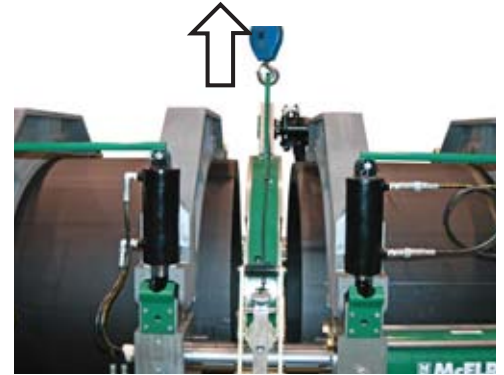

PH04866-3-15-13

TX04563-3-25-13

Determine Drag Pressure

Drag pressure should be determined using the following procedure:

Move the carriage so that the faced pipe ends are approximately 2" apart.

Shift the carriage control valve to the middle (neutral) position.

Select the heating mode, and adjust the middle pressure reducing valve to its lowest pressure by turning the valve counterclockwise.

Shift the carriage control valve to the left.

Gradually increase the pressure by turning the valve clockwise. Increase the pressure until the carriage moves.

Quickly reduce the heating pressure valve counterclockwise until the carriage is just barely moving.

Record this actual drag pressure.

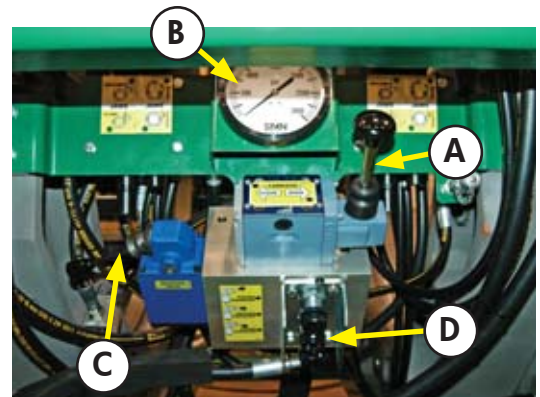

- A - Carriage Control Valve
- B - Pressure Gauge
- C - Pressure Selector Valve
- D - Pressure Reducing Valves (3)

PH04832-3-15-13

TX03023-8-19-09

Set Fusion Pressure

With the selector valve in the down position, the fusion pressure can be set.

The theoretical fusion pressure can be calculated using the enclosed fusion pressure calculator. Always add drag pressure to the theoretical fusion pressure.

Gauge (Fusion) Pressure = Theoretical Fusion Pressure + Drag Pressure



PH04004-8-25-09

TX03024-10-19-10

Check for Slippage

Bring the two sections of pipe together under fusion pressure to make sure they don't slip in the jaws.

If slippage occurs, return to **Loading Pipe into Machine**.

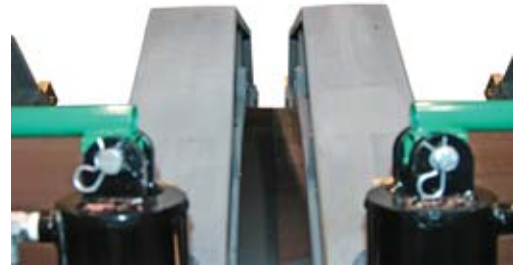

PH04869-3-15-13

TX00971-12-7-10

Check Alignment

Move carriage to the left at facing pressure, until pipe ends contact. Look across the top surface of pipe ends to check alignment. If there is a noticeable step across the joint, adjustments must be made.

Adjusting knobs are located on top of both inner jaws. The jaws must be opened to perform the adjustment. To open the jaws enough to adjust the alignment, open the jaws. Unclamp the jaws, which will allow the jaws to open as they are unclamped. Turn the knob counter-clockwise on the high side jaw to improve alignment. Holding the clamping tie bar, close the jaws and reclamp the jaws with the clamping cylinders.

IMPORTANT: Always adjust the side that is higher, never adjust the low side.

⚠ WARNING Hydraulically operated equipment is operated under pressure. Anything caught in the machine will be crushed. Keep fingers, feet, arms, legs, and head out of the machine while operated.

Insert the facer and reface the pipe ends.

Ensure there is no unacceptable gap between the pipe ends. If there is an unacceptable gap, return to **Loading Pipe into Machine**.



PH04869-3-15-13

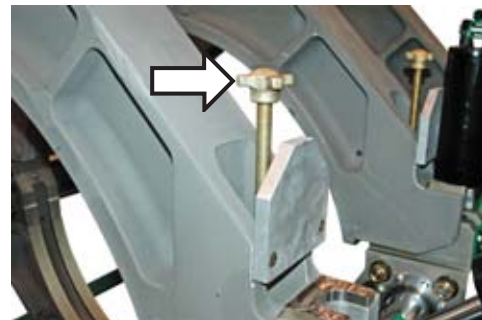

PH04885-3-25-13

TX04564-3-25-13

Remove Heater from Heater/Facer Stand

Attach a lifting device of adequate rating to the lifting eye of the heater. Open the cover of the heater. Lift the heater up from the stand and then away from the heater/facer stand. Position the heater over the carriage between the pipe ends.

Check Heater Temperature:

NOTICE: Incorrect heating temperature can result in questionable fusion joints. Check heater plates periodically with a pyrometer and make necessary adjustments.

Check heater surface temperature.

Refer to the pipe manufacturer's recommendations or appropriate joining standard for proper heater temperature.

Cleaning Heater:

Use a clean non-synthetic cloth to clean the butt fusion heater surfaces.

CAUTION Keep hands clear of the heater while moving into position. Use the handles provided on the heater. Failure to do so could result in minor injury.

CAUTION The heater is hot and will burn clothing and skin. Keep the heater in its insulated heater shroud when not in use, and use care when heating the pipe.



PH04854-3-15-13



WR00077-4-16-93



PH04886-3-25-13

TX04593-4-18-13

Insert Heater

Move the carriage to the right.

Lower the heater between the pipe ends and ensure the rear of the heater is inserted in the notch of the heater stripper. Lower until the heater is completely in the notch and the heater roller rests on the guide rod.



PH04872-3-15-13



PH04893-3-25-13

TX04580-4-5-13

Heat Pipe

Shift the selector valve to the center position, and set the heating pressure (if required). If heating pressure is not required, set the pressure reducing valve at its lowest setting, or the drag pressure, whichever is higher.

Shift the selector valve to the fusion position and move carriage to the left to bring pipe ends in contact with the heater. Move selector valve to middle (heating mode) position. If heater pressure is not required by pipe manufacturer or joining standard, or opposing forces are not great enough to move the carriage away from the heater, shift the carriage control valve to neutral.

IMPORTANT: Always shift into the heating mode **before** returning carriage valve to neutral.

Follow the pipe manufacturer's suggested heating and soaking procedure or joining standard.

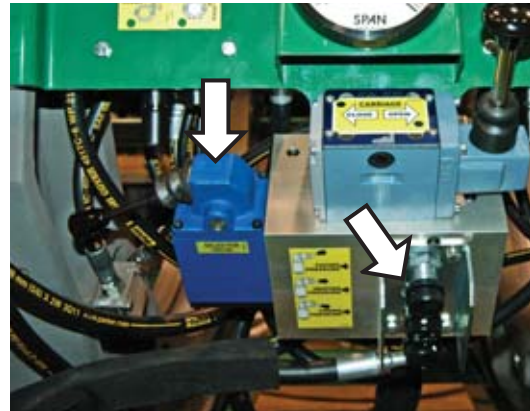

PH048323-15-13

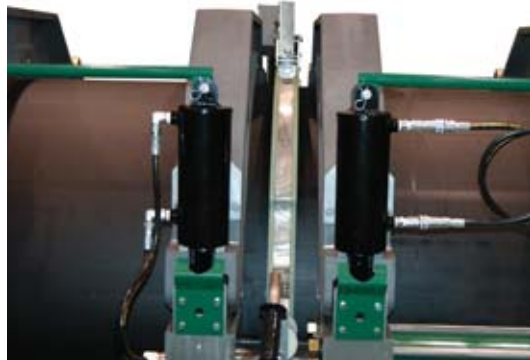

PH04874-3-15-13

TX02880-10-12-10

Fusing the Pipe

NOTICE: Failure to follow the pipe manufacturer's heating time, pressure and cooling time may result in a bad joint.

After following the heating procedure, verify carriage control valve is in neutral and move selector valve down, to fusion position.

Move the carriage to the right and allow the heater to be stripped from the pipe ends.

Quickly lift the heater from between the pipe ends. Ensure the heater does not touch the pipe ends as it is removed.

Quickly inspect pipe ends for appropriate melt.

When heater is clear of the jaws, quickly move the carriage to the left and bring the pipe ends together using the pipe manufacturer's recommended pressure.

Allow joint to cool under pressure according to pipe manufacturer's recommendations or appropriate joining standard.

Visually examine the entire circumference of the joint for compliance with standards established by your company, customer, industry, federal, state, or local regulations.



PH04876-3-15-13

TX04565-3-25-13

Open Jaws

Shift the carriage control valve to the neutral position before opening the jaws.

Unclamp jaws on carriage and open jaws.

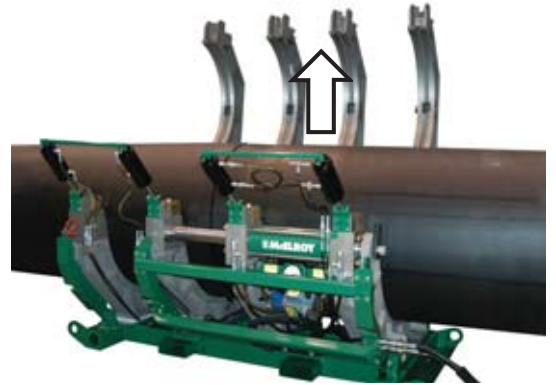

PH04873-15-13

TX04566-3-25-13

Position Pipe for Next Joint

Move the fusion machine to end of pipe, or pull the pipe through the jaws until the end of the pipe is protruding past the jaw face of the fixed jaw.

Insert a new piece of pipe in movable jaws and repeat all previous procedures.

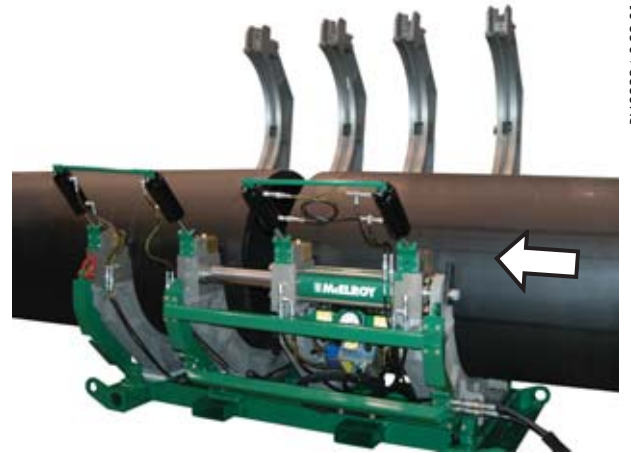

PH0224-8-22-01

TX01682-11-17-10



Special Operations - 3-Jaw



Overview

The 3-Jaw carriage can be separated from the 4-Jaw carriage for in-ditch tie-ins and fusing tees or fittings that have less working space than is possible while the carriage is in the 4-Jaw configuration. The carriage is less stable in the 3-Jaw configuration. Take care to support the machine as needed to prevent tipping.

TX04567-3-25-13



PH04894-3-25-13

Removing 3-Jaw Carriage

Remove the 6 bolts from the inner fixed jaw. There are 3 on one side and 3 on the other side.



PH04887-3-25-13

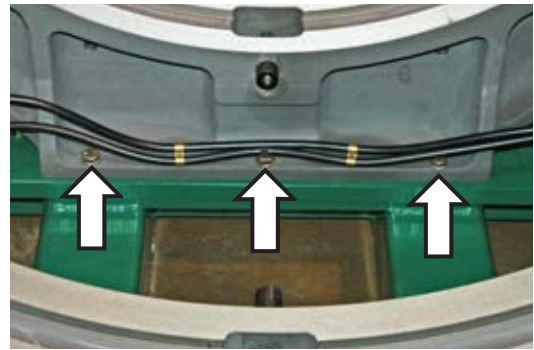

PH04888-3-25-13

Remove the 5 bolts from the guide rod support.

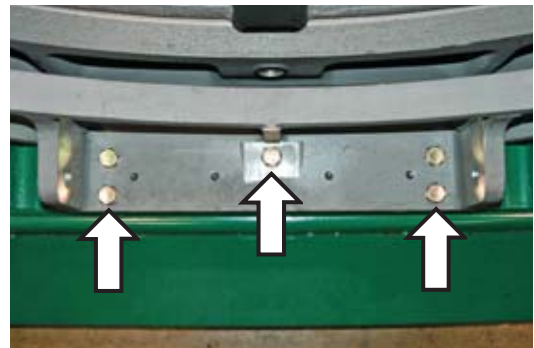

PH04889-3-25-13

Removing 3-Jaw Carriage (continued)

Disconnect the hydraulic lines from both sides of the inner fixed jaw near the bottom of the jaw. Allow the hydraulic lines to lay away from the connection.

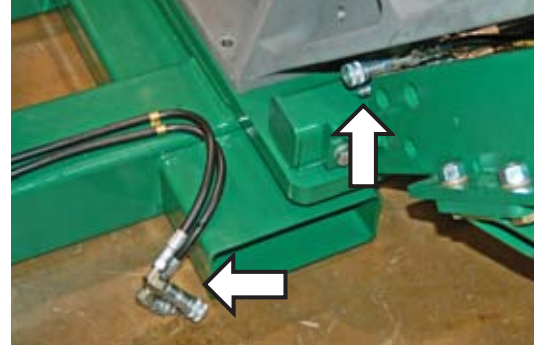

Remove the 3 bolts securing the fixed jaw brace to the inner fixed jaw. Repeat on the fixed jaw brace on the opposite side of the machine.

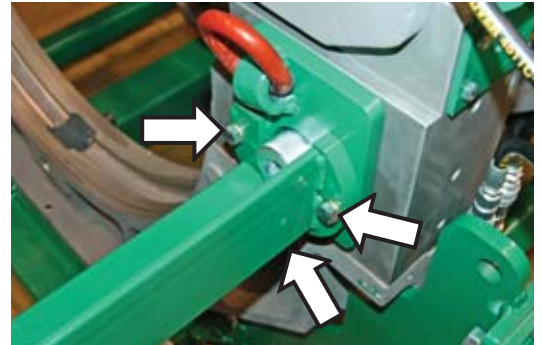

Remove the retaining pin from the clamp cylinder on the inner fixed jaw. Remove the pin holding the tie bar between the two clamping cylinders and rotate the tie bar upward and toward the outer fixed jaw. Replace the pin and retaining pin on the clamping cylinder so it does not get misplaced.



Lift 3-Jaw Carriage

Attach the spreader bar to an appropriate lifting device.

Move the lifting shackles from the outside holes of the spreader bar to the inner holes of the spreader bar.



PH04897-3-25-13

Attach two of the lifting cables to the lift points on both sides of the guide rod support.

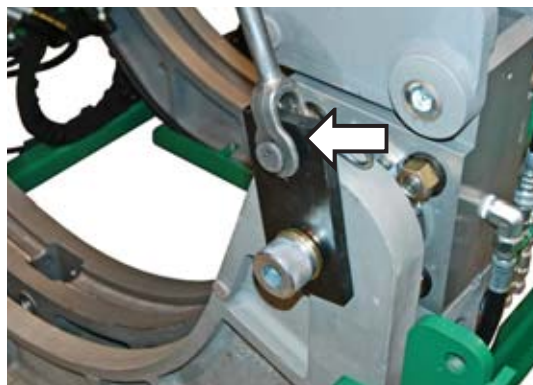

PH04895-3-25-13

Attach remaining two lifting cables to the lifting ring on both sides of the inner fixed jaw.

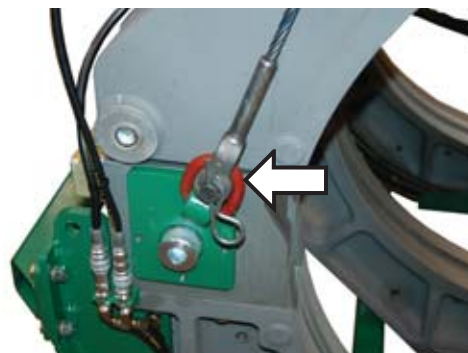

PH04896-3-25-13

Lift the 3-Jaw carriage up from the 4-Jaw skid.

NOTICE: Never use this spreader bar for any other purpose. You could damage the spreader bar and machine.



Special Operations - 3-Jaw



Make Fusion Joint

Refer to the "Operation" section of this manual for operating instructions for making a fusion joint.



PH04876-3-15-13

TX04569-3-28-13

Remove Upper Jaws

The upper jaws of the carriage can be removed so it is easier to maneuver the carriage under pipe in a close quarters in-ditch situation.

Use the shut off valve on the outer most jaws to cut off hydraulic power to those jaws. The valves are located pivot side of the upper jaws. Remove the inner most jaws first then the outer most jaws.

Attach the jaw lifter to the jaw that is to be removed.

Ensure the retaining pin is secured with pins on both sides to prevent the pin from sliding out of the device.

Close the shut off valve of the jaw paired with the inner jaw you are removing.

Open the jaw completely.

Attach lifting device to the jaw lifter.

Loosen the set screw where the hydraulic cylinder attaches to the bottom jaw.

With the drift included in the toolbox, drive the pin out completely and place in the toolbox.

Retract the hydraulic cylinder arm using the jaw controls to close the jaws. The other jaw controlled by that valve will close while the arm of the hydraulic cylinder on the jaw will retract.

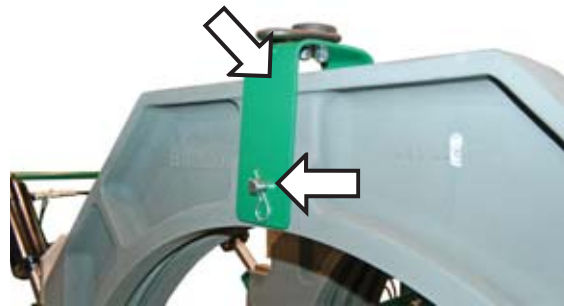

PH04901-4-2-13

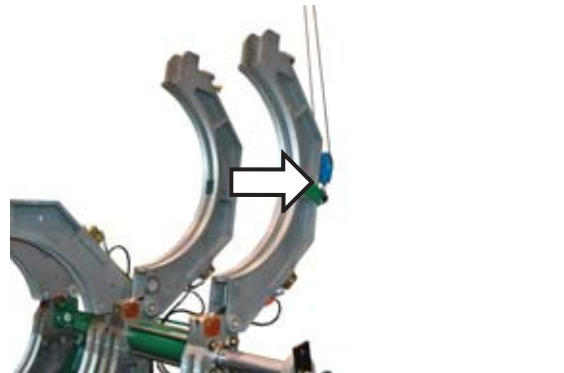

PH04902-4-2-13

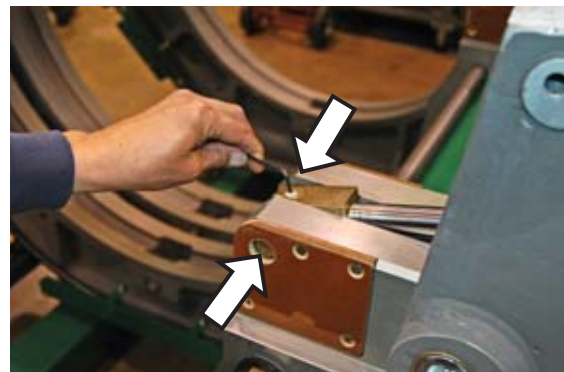

PH04903-4-2-13

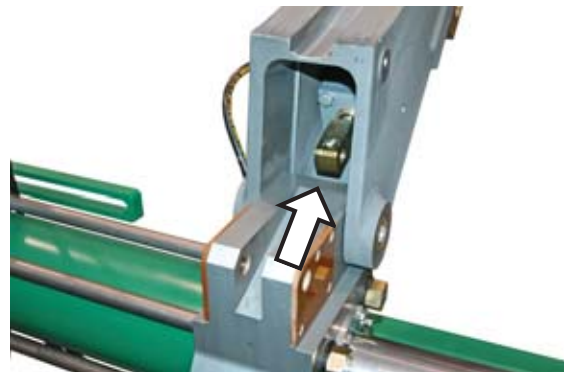

PH04904-4-2-13



Special Operations - Upper Jaws



Remove Upper Jaws (continued)

Turn off the Power Pack. Move the jaw open/close valve to relieve pressure in the hydraulic hoses to the hydraulic cylinder. Disconnect the two quick disconnects going to the hydraulic cylinder.

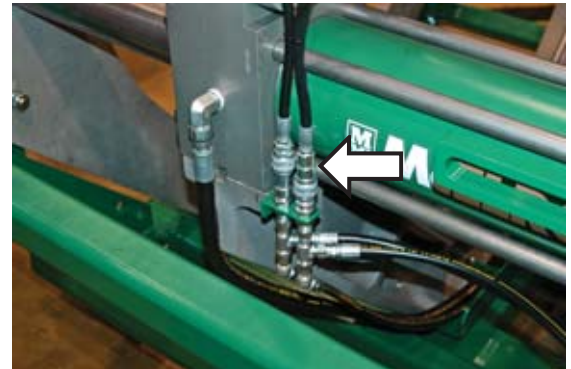

PH04908-4-2-13

Use the lifting device to manually pivot the jaw and lower to the closed position.

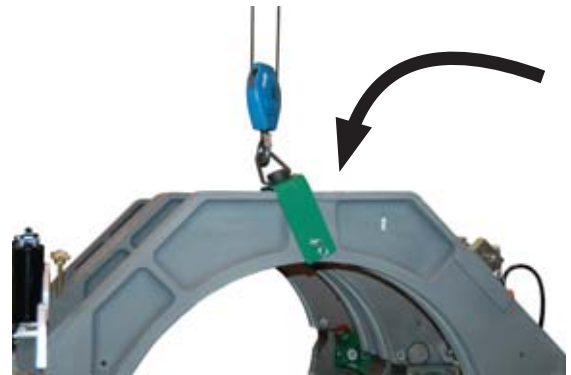

PH04905-4-2-13

Loosen the set screw several turns on the back of the lower jaw. Use the included drift to drive the pin attaching the upper jaw to the lower jaw out. Once the pin is removed, the upper jaw can be lifted away from the carriage. The pin should be placed in the toolbox.

Open the shut off valves for the outer jaws and repeat the procedure until all of the jaws are removed.

To reattach the upper jaws, reverse the procedure. Ensure set screws are tightened and hoses connected. The jaws with the adjustment go on the inner jaws of the machine.

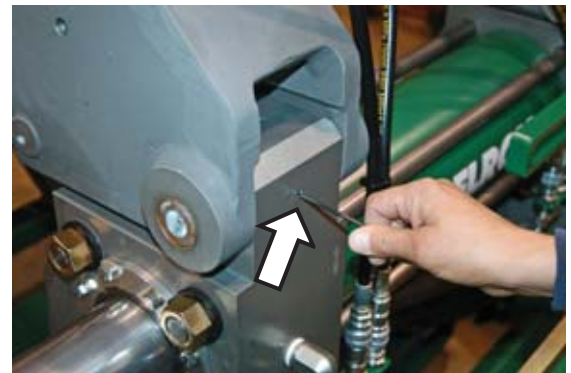

PH04906-4-2-13



PH04907-4-2-13

TX04570-4-2-13



PH04909-4-2-13

Remove Hydraulic Clamping

The hydraulic clamping should be removed if the carriage is going to be rotated and slid under pipe to prevent damage to the hydraulic clamping cylinders.

Disconnect the hydraulic disconnects that connect the clamping cylinder. Connect the two removed quick disconnects together to prevent dirt and debris from covering the fittings.

On the cylinders for the movable jaws, disconnect the quick disconnects between the two clamping cylinders. The clamping cylinders on the fixed jaws have individual quick disconnects.

Remove the pin that attaches the cylinder tie bar to the clamp cylinder. Rotate the tie bar away to the other cylinder.

Push the clamping cylinder back towards the upright position to access the set screw for the clamp cylinder pin. Loosen the set screw.

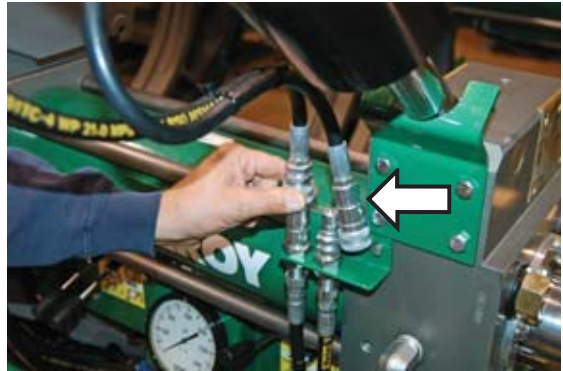

PH04912-4-2-13

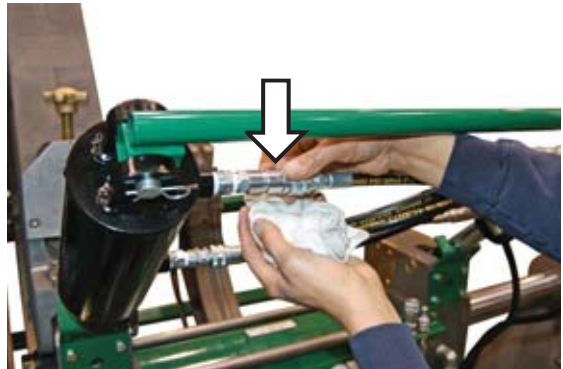

PH04910-4-2-13



PH04911-4-2-13

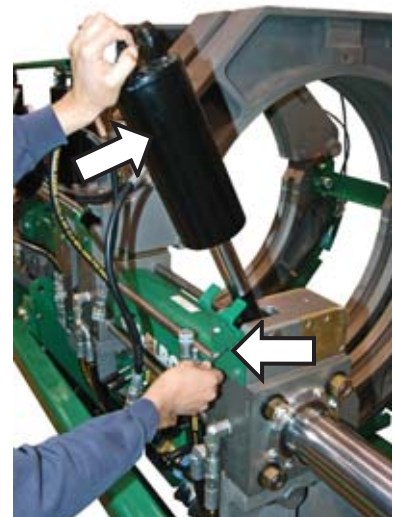

PH04913-4-2-13

Remove Hydraulic Clamping (continued)

Have a second person hold the clamp cylinder while the first person use the drift to drive the pin from the lower jaw. When the pin is removed, the second person can remove the clamp cylinder from the lower jaw.



PH04914-4-2:13

Repeat this procedure until all of the hydraulic clamping cylinders have been removed from the carriage.



PH04915-4-2:13

After the carriage has been moved into position for fusion, reverse the procedures to reinstall all of the hydraulic clamping cylinders. Ensure set screws are tightened and hoses connected.



Lifting Fusion Machine



Lifting Safety

Follow all applicable federal, state, local, and industry specific regulations when lifting.

⚠ WARNING

Safety warnings:

1. Do not exceed rated load or lift loads greater than the rated load rating of the lifting device.
2. Do not operate a damaged or malfunctioning lifting device.
3. Do not lift persons.
4. Do not lift a suspended load over persons.
5. Do not leave a suspended load unattended.
6. Do not remove or obscure warning labels.
7. Read and understand the operator's manual before using the device.
8. Stay clear of the suspended load.
9. Lift loads only as high as necessary.
10. Do not alter or modify the lifting device.
11. Employ generally accepted safe lifting practices.
12. Do not shock or impact load the lifting device.
13. Inspect all lifting pins for damage.



SAFE1st 12-14-92

WR00014-3-8-93



Lifting Fusion Machine



Lifting 4-Jaw Skid

A special spreader bar shipped with the machine has been designed to lift the carriage assembly, and the 3-Jaw carriage.

To lift the 4-Jaw skid, the spreader bar must have the cables attached to the two inner holes of the spreader bar.

NOTICE: Never use this spreader bar for any other purpose. You could damage the spreader bar and machine.

Move the carriage to right (open position).

Attach one set of cables to the red lifting rings on the inside of the outer fixed jaw.

Attach the second set of cables to the two lifting plates mounted to the guide rod support.

The 4-Jaw skid has forklift pockets on its skid if using a forklift is preferred.

Lift the 4-Jaw skid

TX04572-4-5-13

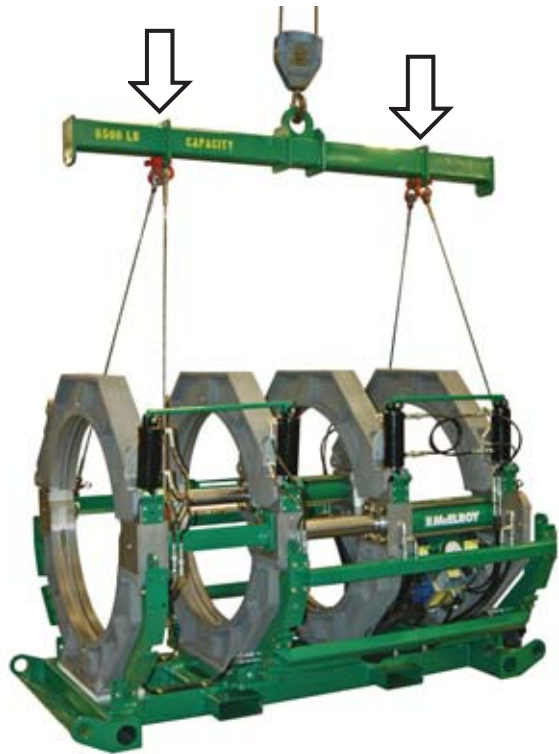

PH04916-4-4-13

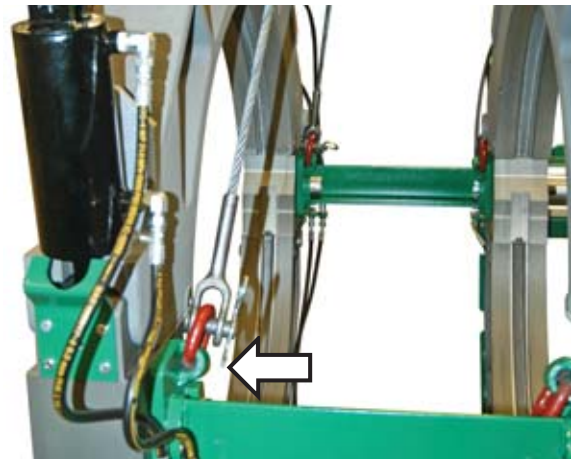

PH04916-4-4-13

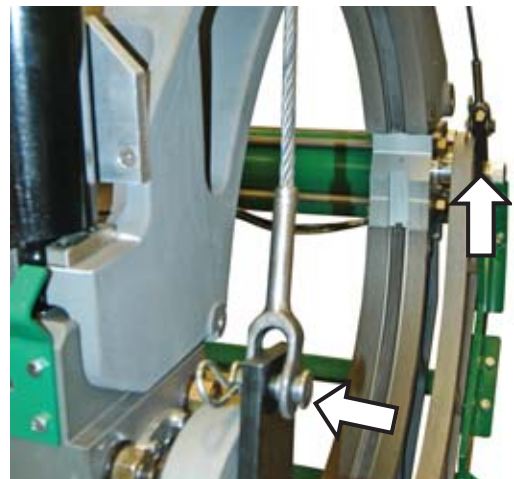

PH04916-4-4-13



Lifting Fusion Machine



Lifting Carriage from a Side

The spreader bar can be used to lift the carriage from the side. This is used to lower the carriage on its side so it can be maneuvered around and under pipe in an in-ditch fusion. The carriage can be lifted from a side in either the 4-Jaw or 3-Jaw configurations.

The carriage has lifting points on the brackets that surround the lower jaw.

For the 4-Jaw configurations, connect the cables to the outside lifting points of the spreader bar.

For the 3-Jaw configurations, connect the cables to the inside lifting points of the spreader bar.

Connect two of the cables from the alternate sides of the spreader bar to the a lift point on outermost brackets of the carriage. There are several points on the bracket that can be used depending on the angle of how the carriage is desired to be lifted. Ensure that you use lifting points that are the same level of the bracket to avoid uneven lifting.



WARNING Stand clear of the carriage during lifting as the carriage will roll over as it is lifted from one side. The carriage is heavy and could result in serious injury or death if the carriage rolls onto an individual.

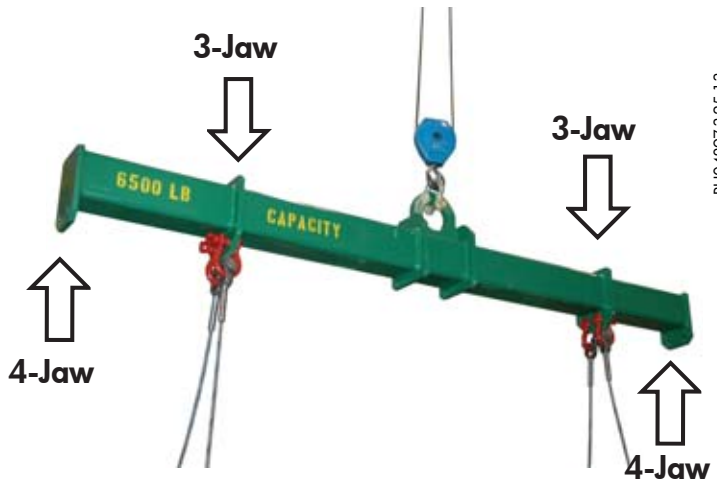

PH04897-3-25-13

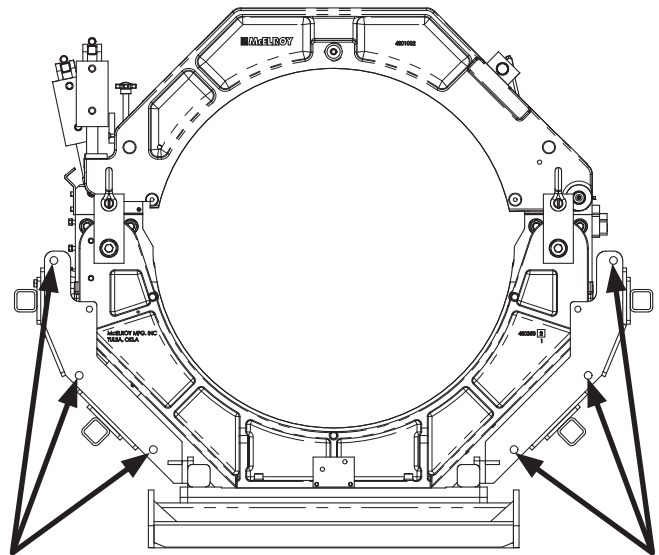

CD01111-4-18-13

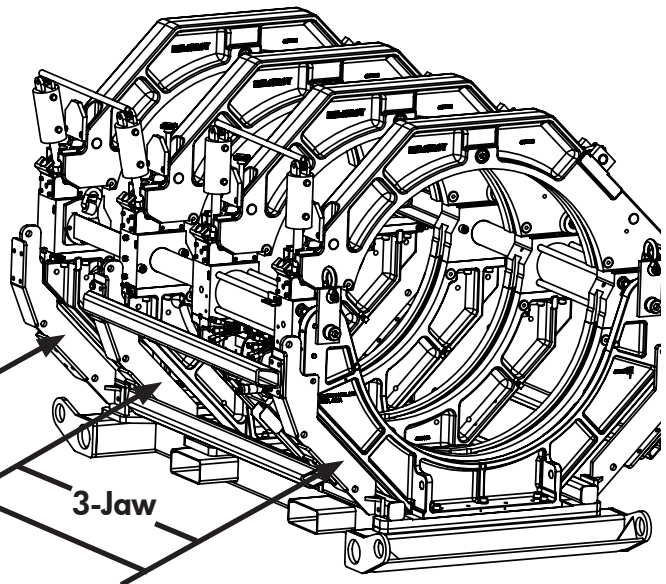
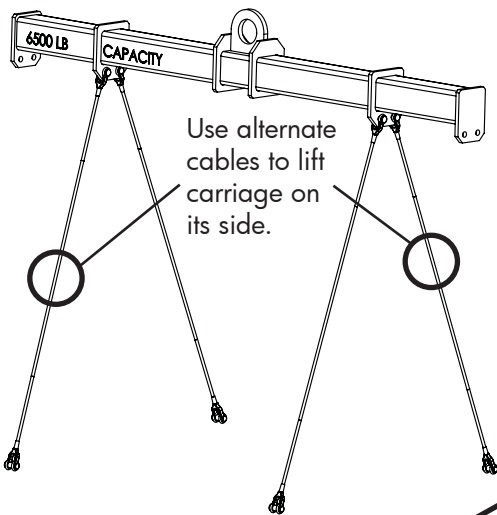

CD01112-4-18-13

CD01113-4-18-13

TX04596-4-18-13



Lifting Fusion Machine



Lifting Heater/Facer Stand

The heater/facer stand can be lifted using the lifting point on the stand between the facer and heater.

Before lifting the stand, the heater and facer need to be secured in the stand.

Remove the pin of the transport arm and rotate the arm up to the vertical position.

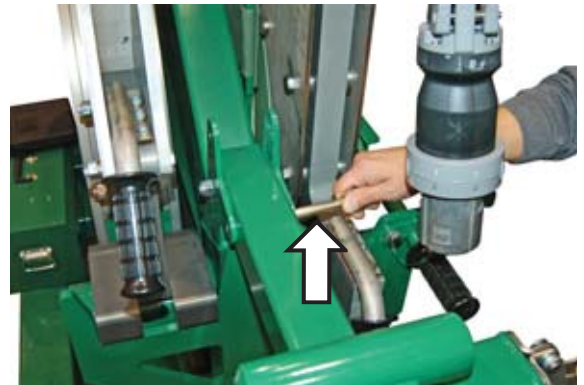

PH04839-3-15-13

Replace the pin, securing the transport arm.



PH04862-3-15-13

Engage both clamp levers for the heater and facer.

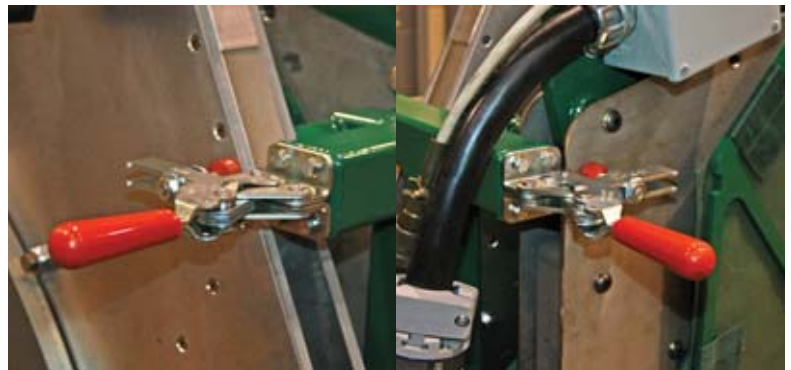

PH04837-3-11-13

PH04838-3-11-13

Attach an adequately rated lifting device to the lifting point of the stand.

NOTICE: Do not attempt to lift the stand using the lifting point of the heater or facer. Doing so will cause damage to the stand and its components.

The stand has forklift pockets on its skid if using a forklift is preferred.

Lift the stand.



PH03521-10-17-07

TX04573-4-5-13

Lifting Fusion Power Pack

The Power Pack can be lifted using the lifting point on the top of the Power Pack in the middle of the top cover.

Before lifting the Power Pack, roll up and secure all the hoses and cables on the hooks of the Power Pack.

Attach an adequately rated lifting device to the lifting point of the Power Pack.

The Power Pack has forklift pockets on its skid if using a forklift is preferred.

Lift the Power Pack.



PH04919-4-5-13



PH04919-4-5-13



Maintenance



Preventative Maintenance

To insure optimum performance, the machine must be kept clean and well maintained.

With reasonable care, this machine will give years of service. Therefore, it is important that a regular schedule of preventative maintenance be kept.

Store machine inside, out of the weather, whenever possible.

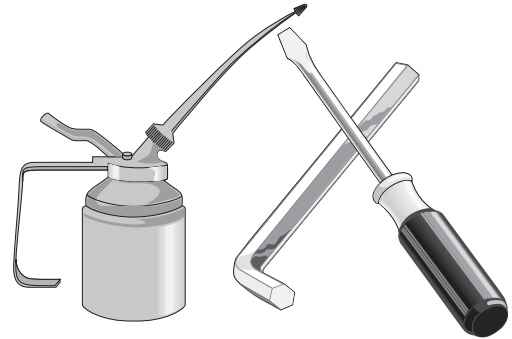

CD00142-11-2-94

TX00428-8-10-95

Disconnect Electrical Power



Always disconnect unit from electrical power source before beginning any maintenance to avoid the risk of electric shock

Cover plug and electrical control box before washing.

Power washing is not recommended.



TX04595-4-18-13

WR00055-4-7-93

Washing the Machine

The machine should be cleaned, as needed, with soap and water.



TX00429-9-15-94

CD00178-5-3-96

Check Hydraulic Fluid

The hydraulic fluid level should be checked daily.

If hydraulic oil is not visible in the sight gauge, oil must be added.

Fill to the top of the sight gauge when the oil is cool.

Refer to the "Hydraulic Fluids" section of this manual for hydraulic oil recommendations.

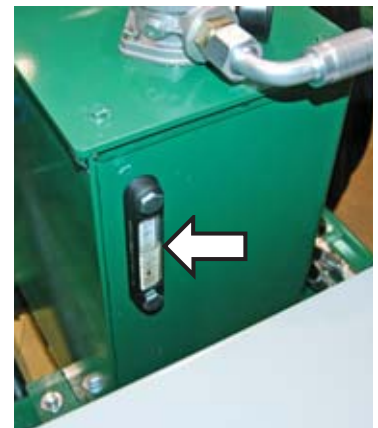

TX04575-4-5-13

PH04856-3-13-13

Change Hydraulic Fluid and Filter

The hydraulic fluid and filter should be replaced after every 500 hours or when the gauge is not green. The magnetic suction filters inside the reservoir should also be disassembled and cleaned.

Use compressed air to remove contamination from the magnetic elements.

Fluid should also be changed as extreme weather conditions dictate. There is a drain plug on the hydraulic reservoir.

Refer to the "Hydraulic Fluids" section of this manual for hydraulic oil recommendations.

TX02889-10-19-10



PH04857-3-13-13

Adjusting System Pressure

The pumps are attached to the electric motor on the side opposite the electrical box of the Power Pack.

To adjust the pressure of the large pump, loosen the jam nut and turn the compensator clockwise to increase the pressure, or counter-clockwise to decrease pressure.

The system pressure should be at 3000 psi.
Re-tighten the jam nut.

TX04576-4-5-13

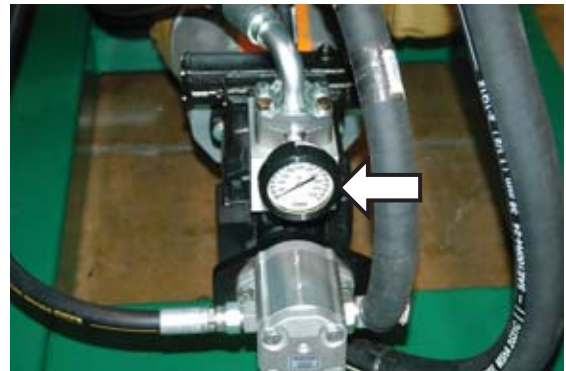

PH04878-3-13-13



PH04879-3-13-13

Grease

Keep moving parts well lubricated as needed with high temperature grease.

Jaw pivot pin

Hydraulic cylinder pivot pins

Facer

TX04583-4-5-13

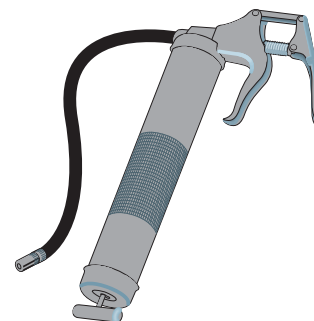

CD00183-11-6-95

Facer Blades

Blades bolt directly to the blade holder and should be inspected for damage and sharpness.

Dull or chipped blades must be replaced.

NOTICE: Never extend the blade beyond the inner or outer circumference of the facer.

TX00439-9-13-94

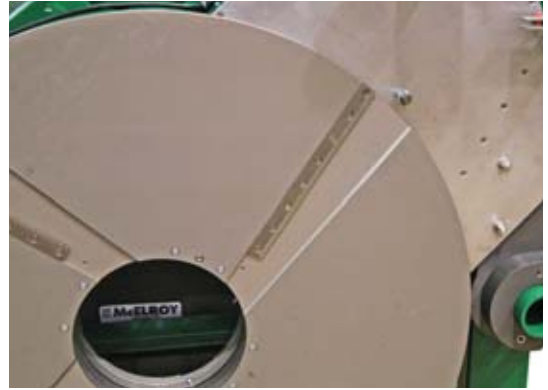

PH04920-3-5-13

Clean Jaws and Inserts

To prevent slippage and insure proper alignment, the jaws and inserts must be clean.

Clean the jaws and inserts of any dirt or residual material using a stiff-bristled brush.

TX00433-9-15-94



PH04921-4-5-13

Installing Butt Fusion Heater Plates

Coated butt fusion heater plates are available for all non-coated heaters.

Butt fusion heater plates are installed with stainless steel cap screws.

Install butt fusion heater plates while the heater is cool.

Care should be taken to assure that the butt fusion heater plates are seated on the heater body, and that there is no foreign matter trapped between these surfaces.

IMPORTANT: Do not over tighten the bolts.

The surface of the butt fusion heater plates are coated with an antistick coating.

TX02716-11-30-10



PH04854-4-5-13

Clean Heater Surfaces

The heater faces must be kept clean and free of any plastic build up or contamination.

Before each fusion joint the heater surfaces must be wiped with a clean, non-synthetic cloth.

NOTICE: Do not use an abrasive pad or steel wool. Use a non-synthetic cloth that won't damage surfaces.

TX00440-8-14-08



PH04886-4-5-13

Bleeding Air From Hydraulic System

Tilt machine so the fixed jaw end is higher than the opposite end.

Shift the directional control and move the carriage to the fixed jaw end. Adjust the pressure to approximately 50-100 psi.

Loosen the bleed plug on one cylinder next to the fixed jaw.

Hold pressure on the cylinder until no air is indicated and quickly retighten the plug.

Repeat bleeding operation on the opposite cylinder.

Tilt the machine so the opposite end is higher than the fixed jaw end.

Move the carriage to the end opposite the fixed jaw end.

Repeat the bleeding procedures for the remaining cylinder.

TX00761-11-15-07

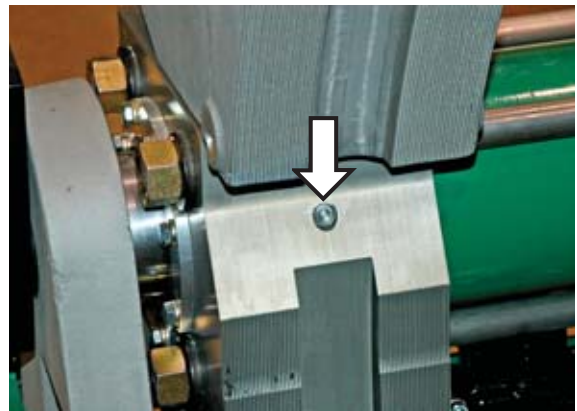

PH04922-4-5-13

Hydraulic Cylinder Cushion

Most hydraulic cylinders are equipped with a cushion which slows the motion of the cylinder near the end of the stroke. There is a set screw near either end of the cylinder to adjust this cushion. The rod end of the cylinder adjusts the opening cushion and the base end of the cylinder adjusts the closing cushion.

To adjust the bottom of the cylinder, open the jaws. Turn off the Power Pack. The bottom adjustment will be visible through the open jaw. Turn the set screw making fine adjustments until the cushion is correct.

To reach the adjustment at the top of the cylinder, ensure the jaws are closed and turn off the Power Pack. Remove the 4 bolts that attach the cylinder to the jaw. Lean the cylinder back to reach the set screw and make a fine adjustment. Reattach the cylinder and check the cushion to see if it is correct.



PH04923-4-5-13

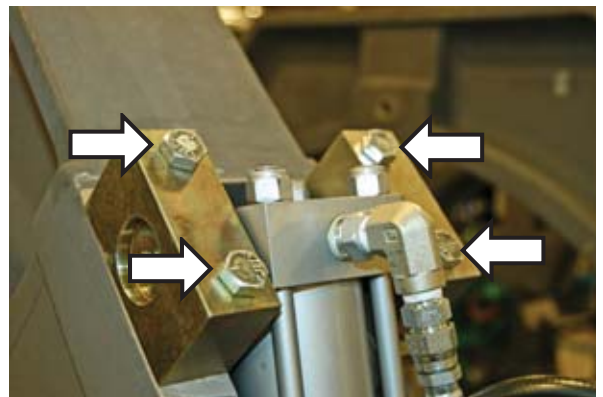

PH04924-4-5-13

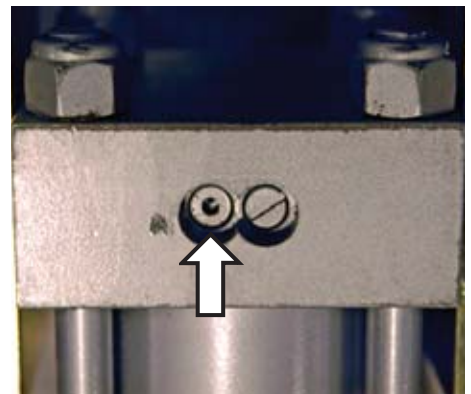

PH04925-4-5-13

Heater Temperature Adjustment

The temperature controller and an on/off switch are located on the front of the electrical box.

Heater surface temperature should be checked periodically with a pyrometer and the necessary adjustment made to the temperature controller.

TX02748-11-30-10



PH04460-11-30-10

Fasteners Must Be Tight

Check all nuts, bolts, and snap rings to make certain they are secure and in place.

TX00437-9-13-94

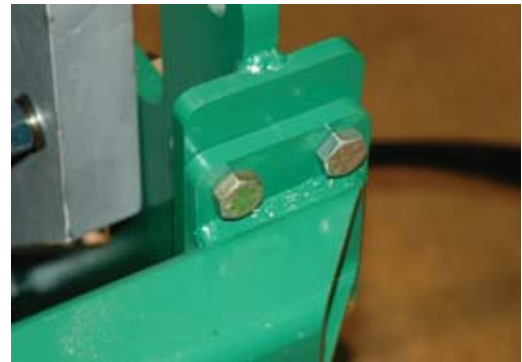

PH04926-4-5-13

If Unit Fails to Start (Power Pack)

Check electrical source to make sure it is sufficient for your machine.

NOTICE: Low voltage will damage unit. Using the phase selector switch and observing the volt meter on the control panel, check voltage at each of the three phases.

⚠ WARNING Disconnect the machine from the power source before attempting to service the control panel. Failure to disconnect the power could result in electric shock. Refer service to a qualified technician.

If unit fails to start, check to see if the light on the reverse phase relay is on. If not, disconnect the power source and switch any two incoming power leads and try again. If the unit still doesn't start, call qualified service personnel for assistance.

Inspect fuses inside electrical box. Replace as required.

TX04577-4-5-13

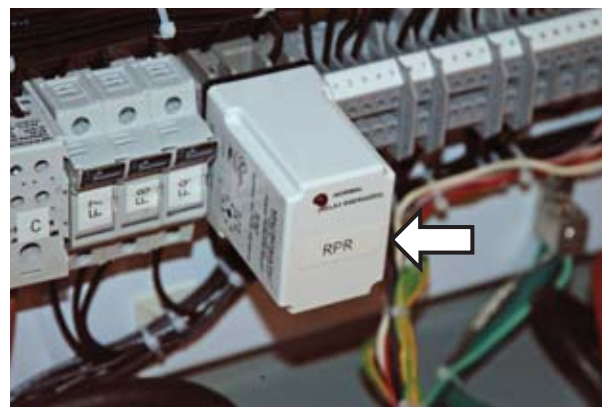

PH04859-3-13-13

Fuji Model PXR3 Temperature Controller Setup

Setting the heater temperature

Turn the heater on and press the SEL key to display the SV (Setting Value). The SV indicator lamp will be illuminated. Press the ▲ (UP) or ▼ (DOWN) arrow keys until the desired setting is displayed. The new value will be registered in the SV after three seconds. Thereafter, the controller will operate using the new SV value.

Checking the heater with a pyrometer

Each day the operator should check the surface of the heater to see that the PV (Process Value) reading on the controller agrees with the actual surface temperature. When the heater has come up to operating temperature, use a hand-held pyrometer or DataLogger® to read the actual surface temperature. Be sure to allow enough time after the heater is turned on for the surface to stabilize. If a discrepancy is detected and the difference is consistent, the operator can modify the controller bias setting as described below.

Adjusting the Controller Bias Setting

Press and hold the SEL key for approximately 6 seconds until the $P_{\Delta}F$ (PVOF) parameter is displayed. Press the SEL key once to display current offset. Use the ▲ (UP) and ▼ (DOWN) arrow keys to adjust the setting to the desired offset value. To increase the heater surface temperature, the offset should be a negative (-) number. Press the SEL key once and $P_{\Delta}F$ (PVOF) will be displayed and the new offset value will be added or subtracted from the SV setting. Press the SEL key for two seconds, to return to the SV setting. After approximately thirty seconds the display will return to the PV reading.

Perform Auto-Tune

Auto-tuning determines the PID values (proportional band, integral time and derivative time) for optimum heater performance. Press and hold the SEL key for approximately 3 seconds. AT (AT) will be displayed. Press the SEL key once. Use ▲ (UP) key to change AT (AT) to 1. Push SEL key once to accept the new AT (AT) value. The unit will begin auto-tuning. The lamp at the bottom right of the display will flash until auto-tuning is complete. AT (AT) value will automatically be reset to 0.



Removing masking

The factory setup hides most of the parameters. The first part of this procedure removes the masking so the parameters can be verified or changed. The final part of this procedure reinstalls the masking to prevent the parameters from being inadvertently changed.

1. Hold SEL button until display shows *dSP 1* Push SEL to access value.
Use Δ ∇ to change value to *96* Push SEL to enter new value.
2. Push ∇ until display shows *dSP2* Push SEL to access value.
Use Δ ∇ to change value to *252* Push SEL to enter new value.
3. Push ∇ until display shows *dSP3* Push SEL to access value.
Use Δ ∇ to change value to *128* Push SEL to enter new value.
4. Push ∇ until display shows *dSP4* Push SEL to access value.
Use Δ ∇ to change value to *13* Push SEL to enter new value.
5. Push ∇ until display shows *dSP5* Push SEL to access value.
Use Δ ∇ to change value to *128* Push SEL to enter new value.
6. Push ∇ until display shows *dSP6* Push SEL to access value.
Use Δ ∇ to change value to *1* Push SEL to enter new value.
7. Push ∇ until display shows *dSP7* Push SEL to access value.
Use Δ ∇ to change value to *0* Push SEL to enter new value.
8. Push ∇ until display shows *dSP8* Push SEL to access value.
Use Δ ∇ to change value to *0* Push SEL to enter new value.
9. Push ∇ until display shows *dSP9* Push SEL to access value.
Use Δ ∇ to change value to *0* Push SEL to enter new value.
10. Push ∇ until display shows *dP 10* Push SEL to access value.
Use Δ ∇ to change value to *111* Push SEL to enter new value.
11. Push ∇ until display shows *dP 11* Push SEL to access value.
Use Δ ∇ to change value to *255* Push SEL to enter new value.
12. Push ∇ until display shows *dP 12* Push SEL to access value.
Use Δ ∇ to change value to *255* Push SEL to enter new value.
13. Push ∇ until display shows *dP 13* Push SEL to access value.
Use Δ ∇ to change value to *127* Push SEL to enter new value.
14. Turn temperature controller off for a few seconds and turn it back on.

Enter 1st Block Parameters

- | | | | |
|----|--|-------------|------------------------------|
| 1. | Hold SEL until display shows | <i>5tby</i> | Push SEL to access value. |
| | Use $\Delta \nabla$ to change value to | OFF | Push SEL to enter new value. |
| 2. | Push ∇ until display shows | <i>PrOG</i> | Push SEL to access value. |
| | Use $\Delta \nabla$ to change value to | OFF | Push SEL to enter new value. |
| 3. | Push ∇ until display shows | <i>LRCH</i> | Push SEL to access value. |
| | Use $\Delta \nabla$ to change value to | 0 | Push SEL to enter new value. |
| 4. | Push ∇ until display shows | <i>AF</i> | Push SEL to access value. |
| | Use $\Delta \nabla$ to change value to | 0 | Push SEL to enter new value. |
| 5. | Push ∇ until display shows | <i>FT-1</i> | Push SEL to access value. |
| | Use $\Delta \nabla$ to change value to | 0 | Push SEL to enter new value. |
| 6. | Push ∇ until display shows | <i>RL 1</i> | Push SEL to access value. |
| | Use $\Delta \nabla$ to change value to | 600 | Push SEL to enter new value. |
| 7. | Push ∇ until display shows | <i>LoC</i> | Push SEL to access value. |
| | Use $\Delta \nabla$ to change value to | 0 | Push SEL to enter new value. |
| 8. | Turn temperature controller off for a few seconds and turn it back on. | | |

Enter 2nd Block Parameters

- | | | | |
|-----|--|-------------|------------------------------|
| 1. | Hold SEL until display shows | <i>P</i> | Push SEL to access value. |
| | Use $\Delta \nabla$ to change value to | 5.0 | Push SEL to enter new value. |
| 2. | Push ∇ until display shows | <i>z</i> | Push SEL to access value. |
| | Use $\Delta \nabla$ to change value to | 240 | Push SEL to enter new value. |
| 3. | Push ∇ until display shows | <i>d</i> | Push SEL to access value. |
| | Use $\Delta \nabla$ to change value to | 60.0 | Push SEL to enter new value. |
| 4. | Push ∇ until display shows | <i>HY5</i> | Push SEL to access value. |
| | Use $\Delta \nabla$ to change value to | 1 | Push SEL to enter new value. |
| 5. | Push ∇ until display shows | <i>CoOL</i> | Push SEL to access value. |
| | Use $\Delta \nabla$ to change value to | 1.0 | Push SEL to enter new value. |
| 6. | Push ∇ until display shows | <i>db</i> | Push SEL to access value. |
| | Use $\Delta \nabla$ to change value to | 0.0 | Push SEL to enter new value. |
| 7. | Push ∇ until display shows | <i>FFrL</i> | Push SEL to access value. |
| | Use $\Delta \nabla$ to change value to | PID | Push SEL to enter new value. |
| 8. | Push ∇ until display shows | <i>FL</i> | Push SEL to access value. |
| | Use $\Delta \nabla$ to change value to | 18 | Push SEL to enter new value. |
| 9. | Push ∇ until display shows | <i>FL2</i> | Push SEL to access value. |
| | Use $\Delta \nabla$ to change value to | 30 | Push SEL to enter new value. |
| 10. | Push ∇ until display shows | <i>P-n2</i> | Push SEL to access value. |
| | Use $\Delta \nabla$ to change value to | 1 | Push SEL to enter new value. |
| 11. | Push ∇ until display shows | <i>P-5L</i> | Push SEL to access value. |
| | Use $\Delta \nabla$ to change value to | -200 | Push SEL to enter new value. |

Enter 2nd Block Parameters (continued)

- | | | | |
|-----|---|--|---|
| 12. | Hold SEL until display shows
Use Δ / ∇ to change value to | <i>P-SU</i>
700 | Push SEL to access value.
Push SEL to enter new value. |
| 13. | Push ∇ until display shows
Use Δ / ∇ to change value to | <i>P-dP</i>
0 | Push SEL to access value.
Push SEL to enter new value. |
| 14. | Push ∇ until display shows
Use Δ / ∇ to change value to | <i>P-F</i>
°F | Push SEL to access value.
Push SEL to enter new value. |
| 15. | Push ∇ until display shows
Use Δ / ∇ to change value to | <i>PUDF</i>
0 | Push SEL to access value.
Push SEL to enter new value. |
| 16. | Push ∇ until display shows
Use Δ / ∇ to change value to | <i>SUDF</i>
0 | Push SEL to access value.
Push SEL to enter new value. |
| 17. | Push ∇ until display shows
Use Δ / ∇ to change value to | <i>P-dF</i>
5.0 | Push SEL to access value.
Push SEL to enter new value. |
| 18. | Push ∇ until display shows
Use Δ / ∇ to change value to | <i>ALN 1</i>
1 | Push SEL to access value.
Push SEL to enter new value. |
| 19. | Push ∇ until display shows
Use Δ / ∇ to change value to | <i>SRAF</i>
OFF | Push SEL to access value.
Push SEL to enter new value. |
| 20. | Push ∇ until display shows
Use Δ / ∇ to change value to | <i>PFn</i>
1 | Push SEL to access value.
Push SEL to enter new value. |
| 21. | Push ∇ until display shows
Use Δ / ∇ to change value to | <i>S\bar{u}-1</i>
32 | Push SEL to access value.
Push SEL to enter new value. |
| 22. | Push ∇ until display shows
Use Δ / ∇ to change value to | <i>r\bar{n}1r</i>
0.00 | Push SEL to access value.
Push SEL to enter new value. |
| 23. | Push ∇ until display shows
Use Δ / ∇ to change value to | <i>r\bar{n}1S</i>
0.00 | Push SEL to access value.
Push SEL to enter new value. |
| 24. | Push ∇ until display shows
Use Δ / ∇ to change value to | <i>S\bar{u}-2</i>
32 | Push SEL to access value.
Push SEL to enter new value. |
| 25. | Push ∇ until display shows
Use Δ / ∇ to change value to | <i>r\bar{n}2r</i>
0.00 | Push SEL to access value.
Push SEL to enter new value. |
| 26. | Push ∇ until display shows
Use Δ / ∇ to change value to | <i>r\bar{n}2S</i>
0.00 | Push SEL to access value.
Push SEL to enter new value. |
| 27. | Push ∇ until display shows
Use Δ / ∇ to change value to | <i>S\bar{u}-3</i>
32 | Push SEL to access value.
Push SEL to enter new value. |
| 28. | Push ∇ until display shows
Use Δ / ∇ to change value to | <i>r\bar{n}3r</i>
0.00 | Push SEL to access value.
Push SEL to enter new value. |
| 29. | Push ∇ until display shows
Use Δ / ∇ to change value to | <i>r\bar{n}3S</i>
0.00 | Push SEL to access value.
Push SEL to enter new value. |
| 30. | Push ∇ until display shows
Use Δ / ∇ to change value to | <i>S\bar{u}-4</i>
32 | Push SEL to access value.
Push SEL to enter new value. |

Enter 2nd Block Parameters (continued)

- | | | | |
|-----|--|------------------|------------------------------|
| 31. | Hold SEL until display shows | $\Gamma\Gamma4r$ | Push SEL to access value. |
| | Use $\Delta\nabla$ to change value to | 0.00 | Push SEL to enter new value. |
| 32. | Push ∇ until display shows | $\Gamma\Gamma45$ | Push SEL to access value. |
| | Use $\Delta\nabla$ to change value to | 0.00 | Push SEL to enter new value. |
| 33. | Push ∇ until display shows | $5\bar{u}-5$ | Push SEL to access value. |
| | Use $\Delta\nabla$ to change value to | 32 | Push SEL to enter new value. |
| 34. | Push ∇ until display shows | $\Gamma\Gamma5r$ | Push SEL to access value. |
| | Use $\Delta\nabla$ to change value to | 0.00 | Push SEL to enter new value. |
| 35. | Push ∇ until display shows | $\Gamma\Gamma55$ | Push SEL to access value. |
| | Use $\Delta\nabla$ to change value to | 0.00 | Push SEL to enter new value. |
| 36. | Push ∇ until display shows | $5\bar{u}-6$ | Push SEL to access value. |
| | Use $\Delta\nabla$ to change value to | 32 | Push SEL to enter new value. |
| 37. | Push ∇ until display shows | $\Gamma\Gamma6r$ | Push SEL to access value. |
| | Use $\Delta\nabla$ to change value to | 0.00 | Push SEL to enter new value. |
| 38. | Push ∇ until display shows | $\Gamma\Gamma65$ | Push SEL to access value. |
| | Use $\Delta\nabla$ to change value to | 0.00 | Push SEL to enter new value. |
| 39. | Push ∇ until display shows | $5\bar{u}-7$ | Push SEL to access value. |
| | Use $\Delta\nabla$ to change value to | 32 | Push SEL to enter new value. |
| 40. | Push ∇ until display shows | $\Gamma\Gamma7r$ | Push SEL to access value. |
| | Use $\Delta\nabla$ to change value to | 0.00 | Push SEL to enter new value. |
| 41. | Push ∇ until display shows | $\Gamma\Gamma75$ | Push SEL to access value. |
| | Use $\Delta\nabla$ to change value to | 0.00 | Push SEL to enter new value. |
| 42. | Push ∇ until display shows | $5\bar{u}-8$ | Push SEL to access value. |
| | Use $\Delta\nabla$ to change value to | 32 | Push SEL to enter new value. |
| 43. | Push ∇ until display shows | $\Gamma\Gamma8r$ | Push SEL to access value. |
| | Use $\Delta\nabla$ to change value to | 0.00 | Push SEL to enter new value. |
| 44. | Push ∇ until display shows | $\Gamma\Gamma85$ | Push SEL to access value. |
| | Use $\Delta\nabla$ to change value to | 0.00 | Push SEL to enter new value. |
| 45. | Push ∇ until display shows | $\Pi\sigma d$ | Push SEL to access value. |
| | Use $\Delta\nabla$ to change value to | 0 | Push SEL to enter new value. |
| 46. | Turn temperature controller off for a few seconds and turn it back on. | | |

Enter 3rd Block Parameters

- | | | | |
|----|---------------------------------------|--------------|------------------------------|
| 1. | Hold SEL until display shows | $P-n l$ | Push SEL to access value. |
| | Use $\Delta\nabla$ to change value to | 4 | Push SEL to enter new value. |
| 2. | Push ∇ until display shows | $5\bar{u}-L$ | Push SEL to access value. |
| | Use $\Delta\nabla$ to change value to | 32 | Push SEL to enter new value. |
| 3. | Push ∇ until display shows | $5\bar{u}-H$ | Push SEL to access value. |
| | Use $\Delta\nabla$ to change value to | 550 | Push SEL to enter new value. |

Enter 3rd Block Parameters (continued)

- | | | | |
|-----|------------------------------|--------------|------------------------------|
| 4. | Push ▽ until display shows | <i>dLY 1</i> | Push SEL to access value. |
| | Use △▽ to change value to | 0 | Push SEL to enter new value. |
| 5. | Push ▽ until display shows | <i>R 1hY</i> | Push SEL to access value. |
| | Use △▽ to change value to | 1 | Push SEL to enter new value. |
| 6. | Push ▽ until display shows | <i>R 1aP</i> | Push SEL to access value. |
| | Use △▽ to change value to | 001 | Push SEL to enter new value. |
| 7. | Hold SEL until display shows | <i>dSP 1</i> | Push SEL to access value. |
| | Use △▽ to change value to | 247 | Push SEL to enter new value. |
| 8. | Push ▽ until display shows | <i>dSP2</i> | Push SEL to access value. |
| | Use △▽ to change value to | 255 | Push SEL to enter new value. |
| 9. | Push ▽ until display shows | <i>dSP3</i> | Push SEL to access value. |
| | Use △▽ to change value to | 255 | Push SEL to enter new value. |
| 10. | Hold SEL until display shows | <i>dSP4</i> | Push SEL to access value. |
| | Use △▽ to change value to | 255 | Push SEL to enter new value. |
| 11. | Push ▽ until display shows | <i>dSP5</i> | Push SEL to access value. |
| | Use △▽ to change value to | 247 | Push SEL to enter new value. |
| 12. | Push ▽ until display shows | <i>dSP6</i> | Push SEL to access value. |
| | Use △▽ to change value to | 255 | Push SEL to enter new value. |
| 13. | Hold SEL until display shows | <i>dSP7</i> | Push SEL to access value. |
| | Use △▽ to change value to | 255 | Push SEL to enter new value. |
| 14. | Push ▽ until display shows | <i>dSP8</i> | Push SEL to access value. |
| | Use △▽ to change value to | 255 | Push SEL to enter new value. |
| 15. | Push ▽ until display shows | <i>dSP9</i> | Push SEL to access value. |
| | Use △▽ to change value to | 255 | Push SEL to enter new value. |
| 16. | Hold SEL until display shows | <i>dP 10</i> | Push SEL to access value. |
| | Use △▽ to change value to | 255 | Push SEL to enter new value. |
| 17. | Push ▽ until display shows | <i>dP 11</i> | Push SEL to access value. |
| | Use △▽ to change value to | 255 | Push SEL to enter new value. |
| 18. | Push ▽ until display shows | <i>dP 12</i> | Push SEL to access value. |
| | Use △▽ to change value to | 255 | Push SEL to enter new value. |
| 19. | Push ▽ until display shows | <i>dP 13</i> | Push SEL to access value. |
| | Use △▽ to change value to | 31 | Push SEL to enter new value. |

A complete operations manual for the Fuji PXR3 controller may be downloaded in .pdf form from the following websites:

<http://www.fujielectric.com>

<http://www.bectrol.com>

<http://www.instrumart.com>



Maintenance Checklist



In-Ditch 48 Machine

INSPECTION CHECKLIST		OK
1.	Machine is clean	
2.	Hydraulic oil is visible in reservoir sight glass	
3.	Hydraulic hoses are in good condition	
4.	Hydraulic carriage works smoothly	
5.	All hydraulic cylinders adjusted (cushion, speed and travel)	
6.	All grease points and pivot points lubricated	
7.	No visual oil leaks (hydraulic system)	
8.	All identification placards are on unit	
9.	Wiring & all electrical terminals are in good condition	
10.	Jaws are aligned properly	
11.	Inserts fit and pin properly	
12.	Facer works properly	
13.	Heater in good condition (no nicks or gouges)	
14.	Surface temperature check with a pyrometer	
15.	Switches and buttons work properly	
16.	All hardware is with unit (inserts and pins, etc.)	
17.	System pressure (3000 psi)	
18.	Power cords and plugs in good condition	
19.	All rest buttons in place	
20.	Spreader bar is in good condition	
21.	Hydraulic valves operate properly	
22.	No damage to fusion machine	
23.	Inspect lifting points for damage.	



Determining Fusion Pressure



Variable Definitions

- O.D. = Outside Diameter
- t = Wall Thickness
- Π = 3.1416
- SDR = Standard Dimensional Ratio
- IFP = Manufacturer's Recommended Interfacial Pressure
- TEPA = Total Effective Piston Area

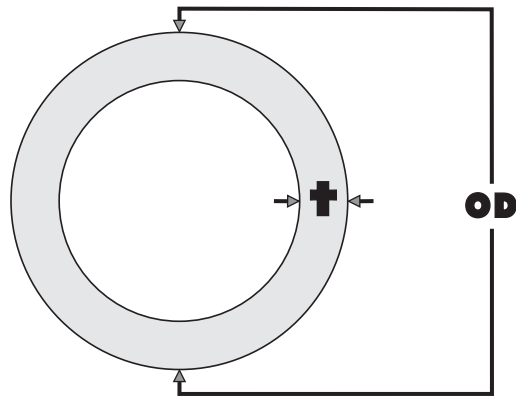

Formulas

$$t = \frac{\text{O.D.}}{\text{SDR}}$$

$$\text{AREA} = (\text{O.D.} - t) \times t \times \Pi$$

$$\text{FORCE} = \text{AREA} \times \text{IFP}$$

$$\text{GAUGE PRESSURE} = \frac{(\text{O.D.} - t) \times t \times \Pi \times \text{IFP}}{\text{TEPA}} + \text{DRAG}$$

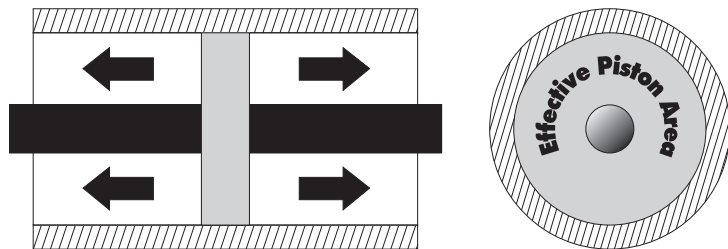

Example

Pipe Size = 8" IPS

O.D. of Pipe = 8.625

DRAG = as measured in PSI (for this example use 30 PSI)

SDR of Pipe = 11

Recommended Interfacial Pressure = 75 PSI

Using a Model 28 Fusion Unit

$$t = \frac{\text{O.D.}}{\text{SDR}} = \frac{8.625}{11} = 0.784$$

TEPA = 4.710 (From Table)

$$\text{GAUGE PRESSURE} = \frac{(\text{O.D.} - t) \times t \times \Pi \times \text{IFP}}{\text{TEPA}} + \text{DRAG}$$

$$\text{GAUGE PRESSURE} = \frac{(8.625 - .784) \times .784 \times 3.1416 \times 75}{4.710} + 30 \text{ PSI} = 338 \text{ PSI}$$

Total Effective Piston Areas

Fusion Model	High Force (Standard)	Medium Force (High Velocity)	Low Force (Extra High Velocity)
28	4.710	-	1.66
412	11.775	6.013	3.142
618	11.775	6.013	3.142
824	29.44	15.32	9.425
1236	29.44	15.32	9.425
1648	31.42	14.14	-
2065	31.42	-	-
1600mm	31.42	14.14	-



Hydraulic Fluids



Hydraulic Fluids

The use of proper hydraulic oil is mandatory to achieve maximum performance and machine life. Use a clean, high quality, anti-wear hydraulic oil with a viscosity index (VI) of 135 minimum. It should have a maximum viscosity of 500 cSt (2000 SSU) at startup (ambient temperature) and a minimum viscosity of 13 cSt (65 SSU) at the maximum oil temperature (generally 80°F above ambient). Using hydraulic oils that do not meet these criteria may cause poor operation and/or damage to the hydraulic components.

The following table specifies the oil temperature at various viscosities. Temperature rise of the hydraulic oil can vary from 30° F to about 80° F over the ambient temperature depending on the pressure setting, age of the pump, wind, etc. Mobil Unavis N46 hydraulic oil is installed at our factory. The advantage of this oil is a wider temperature range, however, this oil should not be used for continuous operation below 24°F.

NOTE: The Mobil DTE 10 Excel series replaced the DTE 10M Series. The Exxon Unavis N series are now Mobil Unavis N.

Hydraulic Fluids Characteristics																	
Manufacturer	Fluid Name	cSt 100F	cSt 210F	V.I.	-20F	-10F	0F	10F	30F	50F	70F	90F	110F	130F	150F	Range °F	Range °C
Mobil	10 Excel 15	15.8	4.1	168	*****	*****	*****	*****	*****	*****	*****	*****	*****	*****	*****	-16 - 113	-27 - 45
	10 Excel 32	32.7	6.6	164				*****	*****	*****	*****	*****	*****	*****	*****	12 - 154	-11 - 68
	10 Excel 46	45.6	8.5	164				*****	*****	*****	*****	*****	*****	*****	*****	23-173	-5 - 78
	10 Excel 68	68.4	11.2	156				*****	*****	*****	*****	*****	*****	*****	*****	37-196	3 - 91
	Unavis N-32	34.9	6.9	164				*****	*****	*****	*****	*****	*****	*****	*****	12-150	-11 - 66
	Unavis N-46	46	8.5	163				*****	*****	*****	*****	*****	*****	*****	*****	24-166	-4 - 74
	Unavis N-68	73.8	12.1	160				*****	*****	*****	*****	*****	*****	*****	*****	39-193	4 - 89

TX03082223-10

NOTE: This chart is based on pump manufacturer recommendations of 13 to 500 cSt.

NOTE: Temperatures shown are fluid temperatures. – NOT ambient temperatures.



Specifications



In-Ditch 48 Fusion Machine

Dimensions

- Length 4-Jaw: 114" (2,896mm)
- Width 4-Jaw: 85.25" (2,165mm)
- Height 4-Jaw: 72" (1,829mm)
- Length 3-Jaw: 68.5" (1,740mm)
- Width 3-Jaw: 85.25" (2,165mm)
- Height 3-Jaw: 65.5" (1,664mm)
- 4-Jaw Centerline Height, Carriage: 40" (1,016mm)
- 3-Jaw Centerline Height, Carriage: 33.25" (845mm)
- 4-Jaw Bottom of Machine to Bottom of Pipe: 16" (406mm)
- 3-Jaw Bottom of Machine to Bottom of Pipe: 9.25" (235mm)
- Maximum Width from Pipe Centerline: 42.5" (1,080mm)
- Minimum Pipe Protrusion After Facing - 3-Jaw: 10" (250mm)

Fusion Machine Weights

- Carriage, 4 Jaws 5,500 lbs (2,495 kg)
- Carriage, 3 Jaws 3,680 lbs (1,669 kg)
- Spreader Bar 380 lbs (172 kg)

Carriage Specifications

- Maximum Pipe Diameter: 48" OD (1200mm)
- Minimum Pipe Diameter: 16" OD (450mm)

- High Force** Effective Piston Area: 31.42 sq in (202.7 sq cm)
 Maximum Force: 94,260 lbs (42,756 kg)

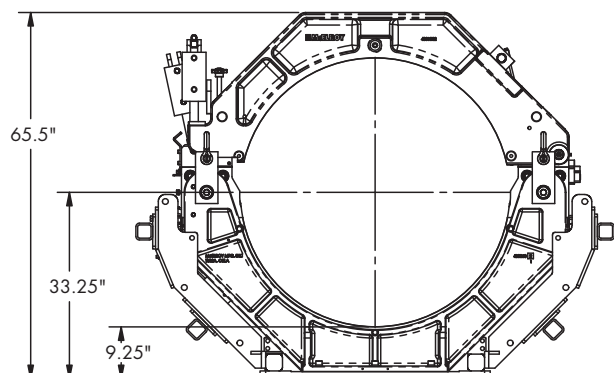
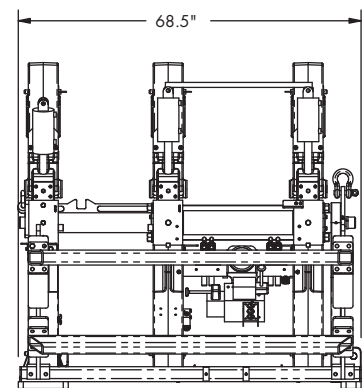
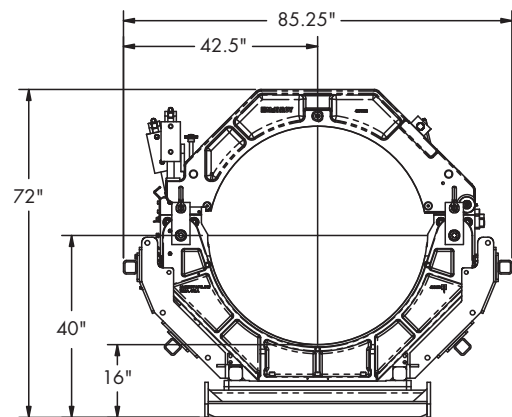
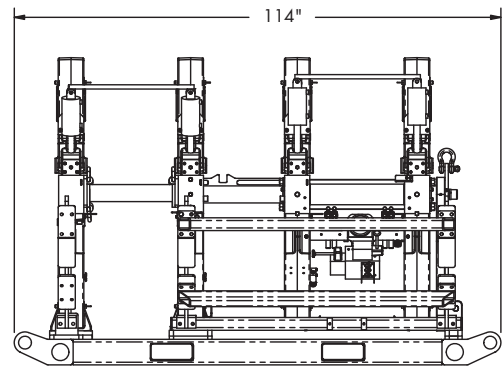



Specifications



In-Ditch 48 Fusion Machine

Fusion Power Pack

Length: 81.5" (2,070mm)

Width: 49.5" (1,257mm)

Height: 65.5" (1,664mm)

Weight: 2780 lbs (1,261 kg)

Motor: 25HP, 3 Phase, 240V, 60hz

35 gal (132.5 liters) Hydraulic Reservoir Capacity

3,000 PSI (206 bar) Operating System pressure

Heater

Length: 82" (2083mm)

Width: 65" (1651mm)

Weight: 695 lbs (315 kg)

Heater Power: 35,000 Watt

Minimum Power Requirement*: 220-240V, 50/60Hz, 3Ph, 160A - 65KVA / 61KW

* minimum requirement at sea level

Facer

Length: 82" (2083mm)

Width: 65" (1651mm)

Weight: 825 lbs (374 kg)

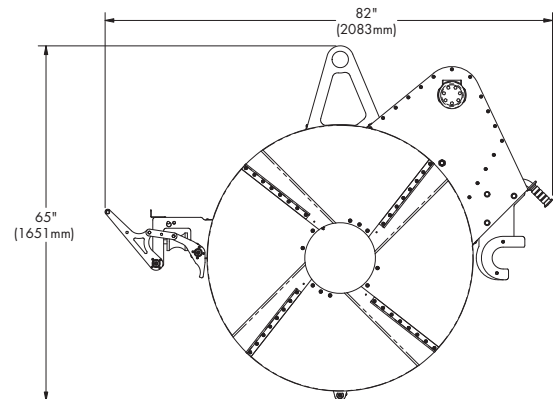
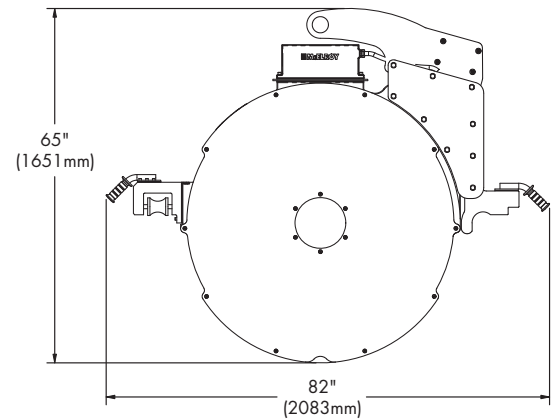
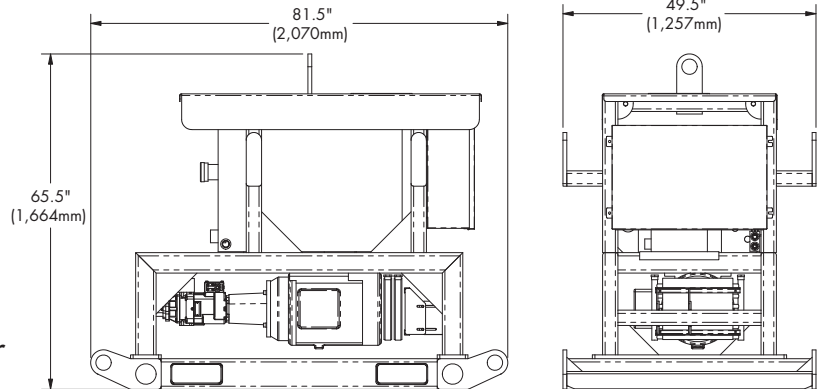

Heater/Facer Stand

Length: 83" (2,108mm)

Width: 49.5 (1,257mm)

Height: 78" (1,981mm)

Weight: 2805 lbs (1,272 kg) (with heater and facer)

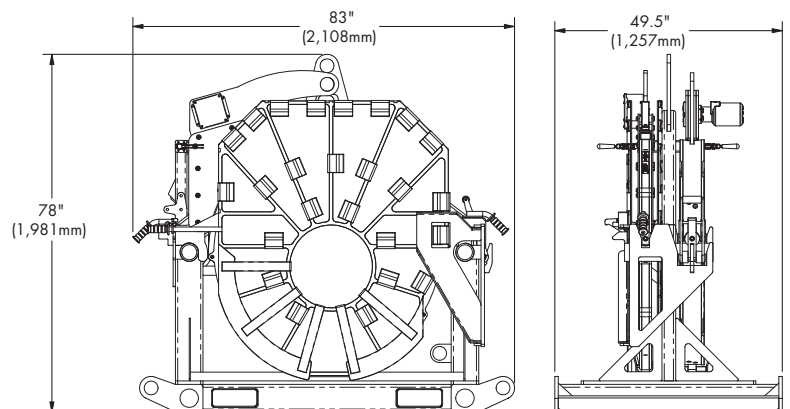

TX04585-10-15-13

About this manual . . .

McElroy Manufacturing continually strives to give customers the best quality products available. This manual is printed with materials made for durable applications and harsh environments.

This manual is waterproof, tear resistant, grease resistant, abrasion resistant and the bonding quality of the printing ensures a readable, durable product.

The material does not contain any cellulose based materials and does not contribute to the harvesting of our forests, or ozone-depleting constituents. This manual can be safely disposed of in a landfill and will not leach into ground water.



The leader by design.

P.O. Box 580550 Tulsa, Oklahoma 74158-0550, USA
www.mcelroy.com