

# HORNET™ XL

Polypropylene outlet fusion for branch sizes 63mm to 160mm  
on to main sizes 110mm and larger



## OVERVIEW

The **Hornet XL** is McElroy's largest all-in-one tool for polypropylene outlet fusion. It brings the same innovative alternative to manual outlet fusion methods in larger outlet sizes up to 160mm and offers a cost-effective option over prefabrication. The Hornet XL's patent-pending design allows it to self-align on the center of the pipe while a guided carriage facilitates the drilling of the outlet hole and fusion of the fitting.

The fitting and drill adapters easily swap in and out of the carriage which keeps the outlet hole and fitting aligned throughout the entire process — creating a more accurate fusion. The drill adapter also resists torque to create a better and smoother operator experience. Guide rod brackets and a built-in stripping mechanism make it easy to maintain control of the heater while pulling it away from molten material.

One person can operate the Hornet which is capable of fusing pipe in any orientation — making it ideal for overhead and vertical fusions. The unique design of the carriage makes it possible to perform socket fusions using standard heater adapters while keeping the machine on the main. The Hornet XL works with all existing McElroy socket and fusion outlet welding heads for polypropylene pipe. An integrated chain clamp system allows it attach to a wide range of main sizes from 110mm and larger while installing outlets for 63mm to 160mm branches.

## FEATURES

- Integrated chain clamp system allows operation across wide range of pipe sizes
- Rack and pinion drive for smooth operation
- Self-centering base design ensures fusion operations align on center of pipe
- Heater alignment guides for even melts
- Carriage brake locks in position
- Drive handle moves from side to side for extra clearance
- Quick change pull pin to easily change standard Acrobat™ inserts
- Pre-pupped outlets can be fused on using existing Acrobat 160 inserts

## SPECIFICATIONS

### CAPACITY

Fuses Pipe Sizes: ..... 63mm – 160mm  
Main Size: ..... 110mm and larger

### MODEL

ASW31401: ..... 110 – 120V  
ASW31402: ..... 220 – 240V

### WEIGHT\*

Machine: ..... 42 lbs. (19 Kg)

### MAXIMUM STROKE

Length: ..... 12-1/2 in. (311mm)

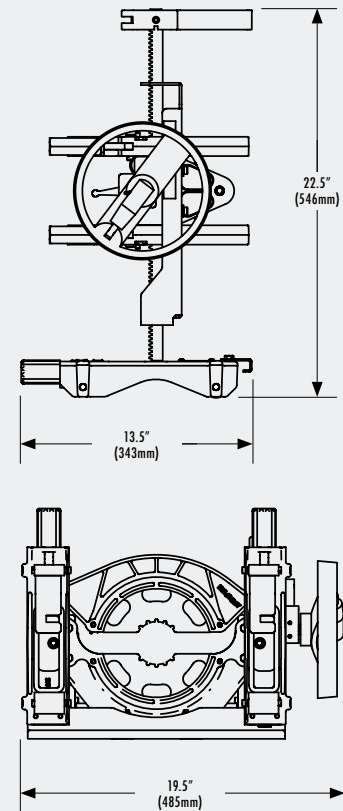

HORNET XL

### INCLUSIONS

Package includes Hornet XL carriage, heater, drill adapter, drill adapter sleeve, 7/16" standard and deep socket, 3/8" square drive, fitting adapter, fitting clamp puck kit, chain extensions, accessory case and carrying case. Drill not included. Cutters and heater adapters sold separately. Specifications subject to change without notice.

\*Carriage weight can be reduced by removing upper jaws, lower jaw inserts, clamp handles, and handle (all done without use of tools) to 34 lbs. (15.5 kg).

