

# ACROBAT™ 450/500 SIZE PACKAGE

Fusion capability for 450mm and 500mm (18" and 20") polypropylene pipe

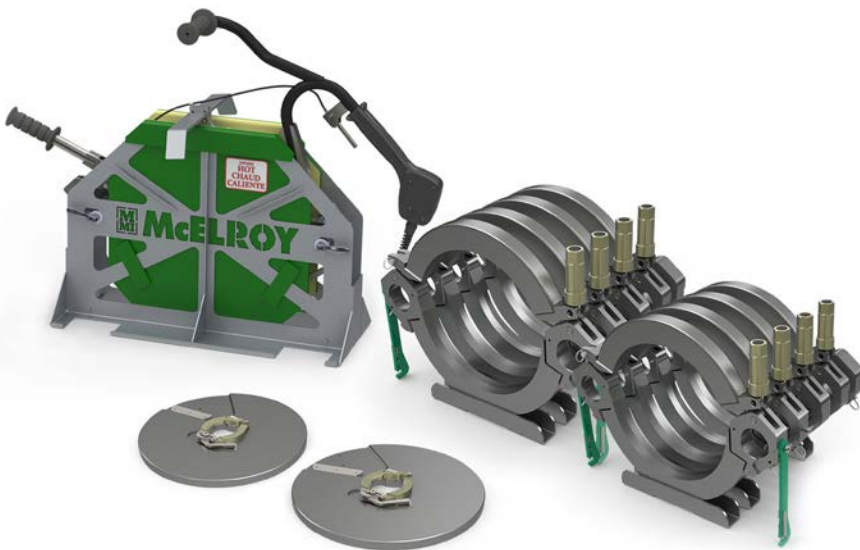

www.sandale.ca



## OVERVIEW

McElroy's Acrobat machines that feature the QuikFit carriage are size specific and are composed of lightweight, modular components so that the upper and lower jaws can be assembled around the pipe by hand. This eliminates the difficulty of lifting and fitting an entire carriage into a small space. It will fuse pipe in any orientation that is required on plumbing, mechanical and HVAC installations, including vertical and overhead.

The **Acrobat 450/500 Size Package** contains the 450mm and 500mm jaws, heater and facer blade holders. All the of components that are common with other size packages, namely the cylinders and clamp assemblies, carriage skid, facer motor, heater/facer cart, facer stand and HPU are grouped together into a **Core Package**. Both packages are required to assemble the carriage.

The unique design of the heater, facer and jaws has significantly reduced the weight and power requirements for this machine.

The Acrobat 450/500 Size Package will fuse 450mm or 500mm pipe.

## FEATURES

- Modular, lightweight carriage and facer assemble around the pipe for optimal close-quarter fusion
- No tools required for assembly or conversion to 3- or 4-jaw unit
- Jaws fit 450 or 500mm pipe - no inserts necessary
- Facer blade orientation allows shavings to fall inside or outside of the pipe
- Stackable shipping container designed to store all machine components

## SPECIFICATIONS

### CAPACITY

Fuses Pipe Sizes:.....450mm and 500mm (18" and 20")

### MODEL

A2480102:..... Acrobat 355/400 Size Package + Core Package

A2480302:..... Acrobat 355/400 Size Package only

### POWER REQUIREMENTS

Heater: ..... 200-240V (2,496W), 50/60Hz, 1Ph, 11.3 Amp

### PLUG TYPE

Heater: ..... NEMA 6-20

### WEIGHT

Upper Jaw (450mm/500mm): ..... 7 lbs. (3.2 Kg)/8 lbs. (3.4 Kg)

Lower Jaw (450mm/500mm):..... 21 lbs. (9.5 Kg)/21 lbs. (9.5 Kg)

4-Jaw Carriage w/ skid (450mm/500mm): ..... 242.5 lbs. (110 Kg)/248.5 lbs. (113 Kg)

3-Jaw Carriage (450mm/500mm):..... 156 lbs. (71 Kg)/160.5 lbs. (73 Kg)

Facer Blade Holder Set: ..... 36 lbs. (16 Kg)

Heater: ..... 36 lbs. (16 Kg)

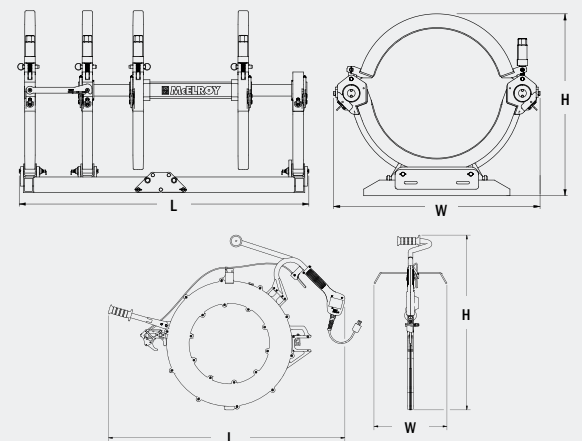

DIMENSIONS	L	W	H
4-Jaw Carriage (450)	55.5" (1,410mm)	32" (813mm)	27.5" (299mm)
3-Jaw Carriage (450)	44" (1,118mm)	32" (813mm)	24.5" (622mm)
4-Jaw Carriage (500)	55.5" (1,409mm)	34" (866mm)	30" (762mm)
3-Jaw Carriage (500)	44" (1,118mm)	34" (866mm)	27" (686mm)
Heater	45" (1,143mm)	15.5" (394mm)	32" (813mm)

### INCLUSIONS

Acrobat 450/500 Size Package includes 450mm and 500mm jaws, heater and facer blade holders. Specifications subject to change without notice.



### TO USE A QUIKFIT CARRIAGE:

A Size Package only contains the jaws, heater and facer blade holders for those specific sizes. To assemble and operate the machine, a Core Package (part number A2480201) is required. See reverse for details.

# ACROBAT™ CORE PACKAGE

For use with Acrobat Size Packages from 355-630mm (14"-24") polypropylene pipe



## OVERVIEW

McElroy's Acrobat machines that feature the QuikFit™ carriage are size specific and are composed of lightweight, modular components so the upper and lower jaws can be assembled around the pipe by hand. This eliminates the difficulty of lifting and fitting an entire carriage into a small space.

The **Acrobat Core Package** contains all the components that are commonly used with all the **Size Packages**. Specifically, it contains the cylinders and clamp assemblies, carriage skid, facer motor, heater/facer rolling cart, facer stand and HPU. Each Size Package contains the jaws, heater, and facer blade holders. Both Size and Core Packages are required to assemble the carriage.

The patent pending facer is powered by a detachable electric motor for easier maneuverability and can also be taken apart for easier handling and added accessibility. A single HPU powers the heater and facer for all carriage sizes and includes a port for DataLogger® capability. The heater/facer rolling cart allows the user to move everything easily from joint to joint.

The Core Package can be used with any Size Package.

## FEATURES

- Modular, lightweight carriage and facer assemble around the pipe for optimal close-quarter fusion
- No tools required for assembly or conversion to 3- or 4-jaw unit
- Core Package can be used with any Acrobat 355-630 Size Package
- Lightweight facer powered by detachable motor for easy maneuverability
- HPU features advanced power management system to minimize peak power draw
- Stackable shipping container designed to store all machine components

## SPECIFICATIONS

### CAPACITY

Fuses Pipe Sizes: .....355mm - 630mm (14"-24")

### MODEL

A2480201:..... Acrobat 355-630 Core Package

### POWER REQUIREMENTS

Facer: ..... 230V (1,700W), 50/60Hz, 1Ph, 7.8 Amp

HPU: ..... 240V (1,700W), 50/60Hz, 1Ph, 20 Amp

Total Power Required (Including heater from Size Package): ..... 10,620W

### PLUG TYPE

Facer: ..... NEMA 6-20

HPU: ..... NEMA L6-30

### WEIGHT

Cylinder Assembly: ..... 46.5 lbs. (21.1 Kg)

Facer Drive Unit: ..... 75 lbs. (34 Kg)

Facer Motor: ..... 21 lbs. (9.5 Kg)

HPU: ..... 170 lbs. (77 Kg)

### HYDRAULICS

Maximum Gauge Pressure: ..... 3000 PSI (206.8 BAR)

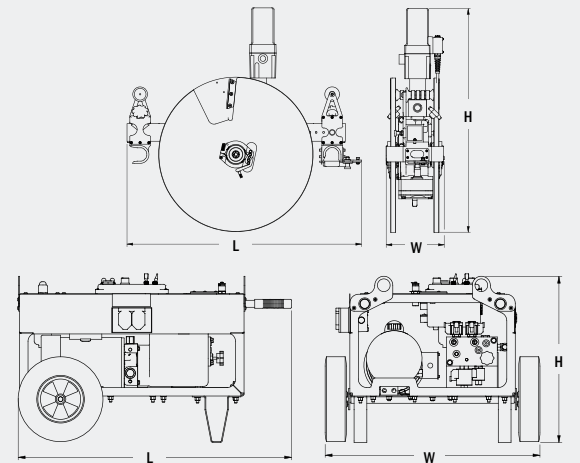

DIMENSIONS	L	W	H
Facer (355 & 400)	40" (1,016mm)	10" (254mm)	33.5" (851mm)
Facer (450 & 500)	40" (1,016mm)	10" (254mm)	35.5" (902mm)
Facer (560 & 630)	40" (1,016mm)	10" (254mm)	38" (965mm)
HPU	32" (813mm)	25.5" (648mm)	19.5" (495mm)

### INCLUSIONS

Acrobat 355 - 630 Core Package includes cylinder assemblies, clamp assemblies, carriage skid, facer motor, facer stand, heater/facer rolling cart, HPU and shipping container. Specifications subject to change without notice.



### TO USE A QUIKFIT CARRIAGE:

A Core Package contains an HPU, facer and hydraulic cylinders. A Size Package (that includes jaws, heater and facer blade holders) is required. See reverse for details.

