

ACROBAT™ 180

Fusion Capability for 63mm to 180mm (2" IPS - 6" DIPS) Pipe



www.sandale.ca



OVERVIEW

The **Acrobat™ 180** is a versatile machine designed for butt fusion of 63mm to 180mm (2" IPS to 6" DIPS) pipe and fittings. The machine offers consistent butt fusion joints — providing a cost-effective alternative to electro-fusion — in an economical, reliable package.

The Acrobat is ideal for in-ditch work. It will convert from 4 to 3 jaws to create a more compact unit and will go even smaller by removing the base plate so that it fuses more easily in confined areas — reducing excavation time.

The fusion carriage is powered by a robust Hydraulic Power Unit (HPU) that is also lightweight and easily portable for quick jobsite setup. This HPU allows the operator to pre-set the facing, heating and fusing pressures individually without having to make adjustments between operations which greatly streamlines the fusion process.

FEATURES

- Small footprint, lightweight
- Toolless conversion of carriage from 4- to 3-jaws for tight work spaces
- Narrow jaws allow fusions for most fittings and flanges
- Hard-anodized aluminum wear surfaces for corrosion resistance
- DataLogger® compatible
- Easy, quick connections to HPU without tools
- Industry-leading 5-Year Warranty
- Single insert design
- Removable upper jaws
- Open-frame HPU design offers easy access for maintenance

SPECIFICATIONS

CAPACITY

Fuses Pipe Sizes:.....63mm – 180mm (2" IPS – 6" DIPS)

MODEL

CARRIAGE FORCE	VOLTAGE	HYDRAULIC POWER UNIT	PART NUMBER
Low	120V	Acrobat HPU	A714801
	220-240V		A714802
	120V	DynaMc EP HPU	A714803
	220-240V		A714804

POWER REQUIREMENTS

	120V	240V
Heater	1.2 kW	0.6 kW
Acrobat HPU	.3 HP, 5.9 Amp	.3 HP, 2.4 Amp
DynaMc HPU	2.2 HP, 14 Amp	2.2 HP, 7 Amp

PLUG TYPE

120V:Nema 5-15

240V:CEE 7/7

WEIGHT

4-Jaw Carriage:.....40 lbs. (18.1 Kg)

3-Jaw Carriage:.....29 lbs. (13.2 Kg)

Facer:.....35 lbs. (15.9 Kg)

Heater:.....14 lbs. (6.4 Kg)

Acrobat HPU:.....56 lbs. (25.4 Kg)

DynaMc HPU:.....115 lbs. (52.1 Kg)

MAXIMUM GAUGE PRESSURE

Acrobat HPU:.....800 PSI (55.2 BAR)

DynaMc HPU:.....1,500 PSI (103.4 BAR)

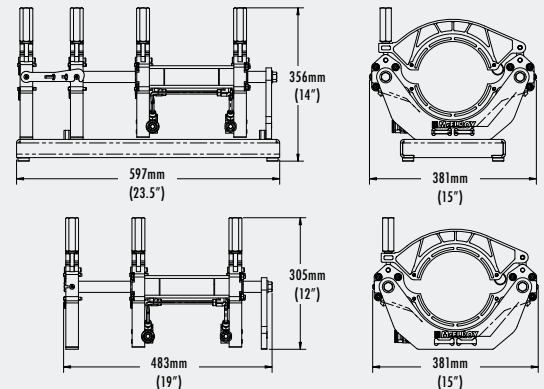

ACROBAT 180

INCLUSIONS

Acrobat 180 package includes fusion machine, facer, heater, insulated heater stand, facer stand, HPU and shipping container. Specifications are subject to change without notice.