

2LC

Fusion Capability for 1/2" CTS to 2" IPS (16mm - 60mm)



The 2LC

SPECIFICATIONS

CAPACITY

Fuses Pipe Sizes:.....1/2" CTS - 2" IPS (16mm - 60mm)

MODELS

A217201:.....100V-120V, 50/60Hz, 800 Watt, 1 Phase Input Voltage Requirement

A217202:.....200V-240V, 50/60Hz, 800 Watt, 1 Phase Input Voltage Requirement

POWER

Heater Power:.....800 Watt

Facer Power:.....Hand-operated

WEIGHT

Machine:.....23 lbs. (10.4 Kg)

Facer:.....7.9 lbs. (3.54 Kg)

Heater:.....7.24 lbs. (3.28 Kg)

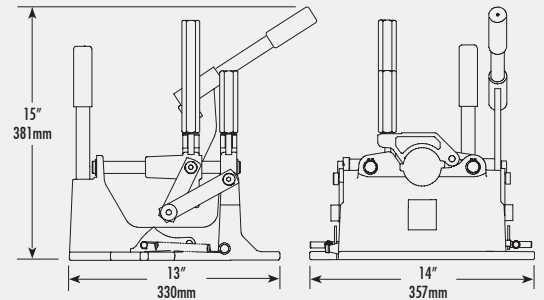

The 2LC

INCLUSIONS

The 2LC includes fusion machine, heater, facer, insulated heater/facer stand and screw/driver kit.

Specifications subject to change without notice.

OVERVIEW

The 2LC will butt fuse 1/2" CTS to 2" IPS (16mm to 60mm) pipe. By employing a semi-automatic locking cam (LC) system, the 2LC expertly maintains force during the cooling cycle.

Designed to butt fuse tees, ells and other fittings, the 2LC incorporates McElroy's patented Centerline Guidance System. The machine is made primarily of surface-hardened aluminum for lightweight and durability. The jaws and inserts have multiple serrations for maximum grip on the pipe.

A range of accessories are available for the 2LC, including a Manual Fusion Machine Stand that brings fusion operations to a comfortable level.

FEATURES

- Locking cam to maintain force during the cooling cycle
- Compact and durable
- 5.8-to-1 mechanical advantage
- Capable of fusing tees, ells and other fittings
- Serrated jaws and inserts keep pipe from slipping during fusion process

